

altronic GTI Bi-Fuel[®]

INSTALLATION & OPERATING MANUAL

GTI BI-FUEL[®] SYSTEM

FORM GTI IOM 4-10



WARNING:

DEVIATION FROM INSTALLATION INSTRUCTIONS AND TECHNICAL GUIDELINES MAY LEAD TO IMPROPER OPERATION OF THE BI-FUEL SYSTEM, DAMAGE OR DESTRUCTION OF THE CONVERTED DIESEL ENGINE AND ASSOCIATED MACHINERY, AND/OR PERSONAL INJURY OR DEATH TO OPERATORS AND NEARBY PERSONNEL.



CAUTION:

THIS MANUAL IS INTENDED FOR USE BY QUALIFIED AND EXPERIENCED TECHNICAL PERSONNEL WITH FORMAL TRAINING IN THE OPERATION AND MAINTENANCE OF HEAVY-DUTY DIESEL ENGINES. THIS MANUAL WAS NEITHER DESIGNED NOR INTENDED AS A TECHNICAL GUIDE TO DIESEL ENGINES AND ASSUMES A HIGH DEGREE OF UNDERSTANDING OF DIESEL ENGINE OPERATION AND THEORY BY THE READER. **ONLY QUALIFIED PERSONNEL SHOULD ATTEMPT INSTALLATION OF THE GTI BI-FUEL SYSTEM.**

1.0 SAFETY PRECAUTIONS

Follow all local codes when installing the Bi-Fuel[®] System. All gas train components should be installed and/or inspected by a licensed plumbing contractor.

- Ensure adequate ventilation in work area in order to prevent accumulation of gas caused by undetected leaks. Accumulations of natural gas or other hydrocarbon vapors can result in high-energy explosions that can damage or destroy structures and cause injury or death to nearby personnel.
- An appropriately rated fire extinguisher must be kept in a readily accessible location during all phases of installation.
- Observe all warnings found on the equipment. Ensure that warning labels are easily legible and not obstructed by dirt, grease or other equipment.
- Do not install any component that appears to have been tampered with, subjected to high temperatures or damaged in any way. Installation of a damaged component may result in gas leaks and/or improper operation of the Bi-Fuel System.
- Do not attempt to operate engine until a thorough leak check has been completed. Use of an industry standard leak detection fluid (such as "Snoop") is required on all gas connections, joints and flanges. **ALL LEAKS MUST BE FIXED PRIOR TO OPERATING ENGINE IN BI-FUEL MODE.**
- All Bi-Fuel System components must be used within the temperature and pressure ranges specified in this manual or as otherwise dictated by component labeling. Operation of components outside of design temperature and pressure limits can result in fire, explosion and/ or harm to personnel.

Note: It is highly recommended that gas detection be installed to protect an enclosed environment against any possible gas leaks.



Note: It is also important to perform leaks tests on all intake manifold and aftercooler components, joints and covers.

2.0 DESCRIPTION AND THEORY OF OPERATION

2.1 GENERAL

The GTI Bi-Fuel System is a retrofit technology that allows diesel engines to operate on a mixture of diesel fuel and natural gas. This is achieved through the use of proprietary and patented technologies that are installed externally of the engine. Conversion to GTI Bi-Fuel requires no major changes or modifications of the engine and allows the engine to operate on natural gas mixtures of up to **70%** of total fuel consumed. After conversion to Bi-Fuel, the engine can still be operated on **100%** diesel fuel without loss of power or efficiency. The Bi-Fuel System has been designed to allow for switching of fuel modes during full or part load conditions, without interruption in engine speed, power or stability. The Bi-Fuel System utilizes a fumigation gas delivery method whereby gas is delivered to the cylinders via the standard engine air-intake system and is then ignited by a diesel “pilot” which acts as an ignition source for the air-gas mixture.

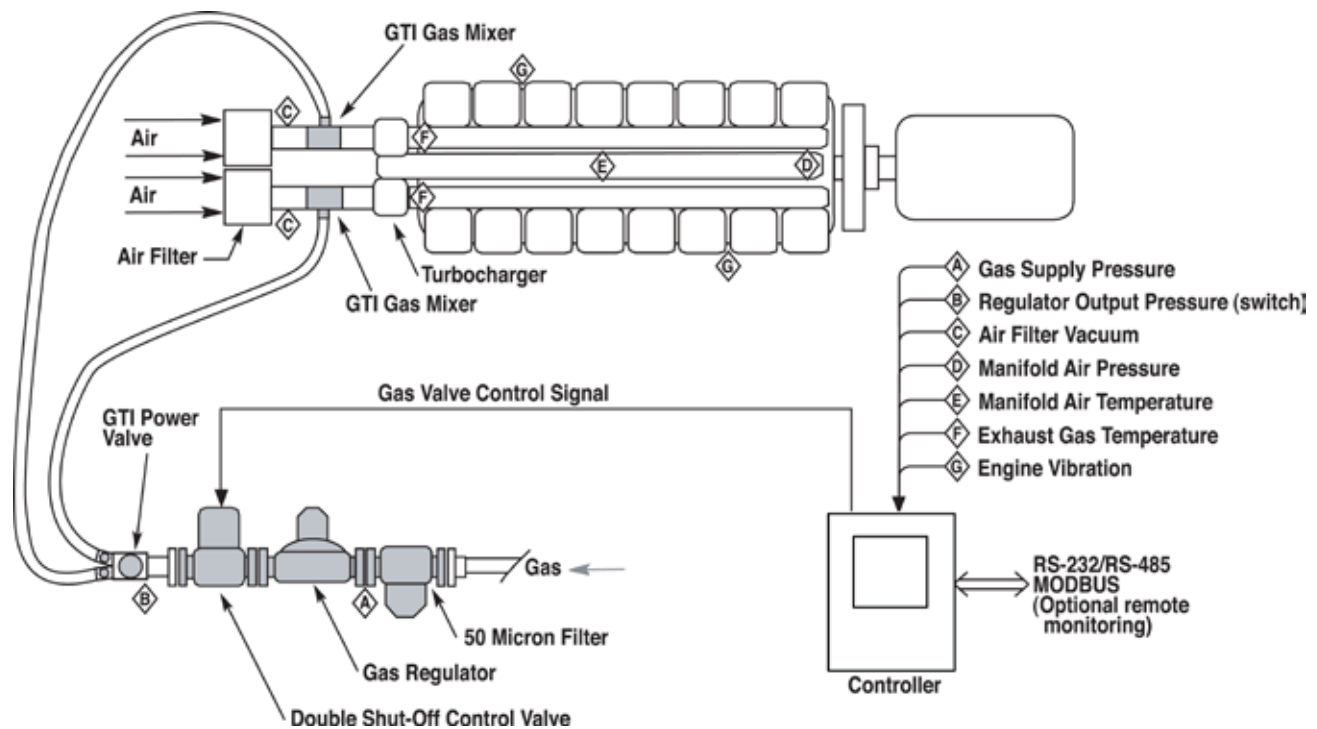

GTI Bi-Fuel System Diagram

Two versions of the Bi-Fuel system are available, the standard system described above which regulates gas flow in a constant manner based upon air flow into the engine, and an optional Dynamic Gas Control System (**DGCS**) version which independently adjusts the flow of natural gas to achieve an optimum gas substitution percentage based upon load. The **DGCS** system utilizes a generator **KW** sensor as an indicator of engine load, and also measures diesel fuel flow continuously. In order to control the Bi-Fuel substitution rate in a

closed loop manner, a fuel flow modulation valve, regulated by the Controller, is added between the fuel pressure regulator and the mixer. Supplemental instructions are supplied with the DGCS kit and should be used in combination with these instructions when this option is installed.

Note: Engine must be equipped with an ISOCHRONOUS governor to operate properly with the GTI Bi-Fuel system.

2.2 APPLICATIONS

The Bi-Fuel System has been designed for constant speed applications such as engine-driven electric power generators, engine-driven pumps, compressors and other industrial and commercial applications. Variable speed applications may also be converted to Bi-Fuel depending on the governing system used and the method of engine operation. The Bi-Fuel System has been designed for continuous-duty operations such as prime power generation and oil field pumping operations.

Note: These instructions apply only to diesel engines equipped with turbochargers. For all non-turbo applications, consult the factory prior to installation.

2.3 COMPATIBLE FUEL TYPES

The Bi-Fuel System is compatible with methane-based fuels such as natural gas, wellhead gas, landfill gas and digester gas. Hydrocarbon gasses such as propane and butane are not compatible with Bi-Fuel operation (in pure form) due to unfavorable combustion characteristics of these fuels. Gas quality and composition are critical factors for Bi-Fuel operation. Ideally, pipeline supplied gas will have a high concentration of methane and a low overall concentration of heavier hydrocarbon gasses (see table). For lower quality gasses (pipeline supplied or other), reductions in engine performance and/or gas substitution rate may be required.

Methane	Ethane	Propane	Butane	Nitrogen	Carbon	Oxygen
97.09	0.88	0.26	0.09	1.41	0.12	–

High Quality Pipeline Gas/Composition in Volume %

2.4 BI-FUEL SYSTEM SIZING

The Bi-Fuel System has been designed as a scaleable technology that can be adapted to various engine sizes. Standard Bi-Fuel System models are typically applied to high speed (>1200RPM) diesel engines up to 4000 horsepower (3000KW). The Bi-Fuel System is offered in five standard models with each model covering a range of engine or generator power (hp or kWe).

Model	Kilowatt Electric	Engine Horsepower
Series A	Up to 150kWe	Up to 200HP
Series I	Up to 300kWe	Up to 400HP
Series II	350 – 600kWe	450 – 800HP
Series III	650 – 1100kWe	850 – 1400HP
Series IV	1200 – 3000kWe	1600 – 4000HP

GTI Bi-Fuel Kit Application Chart

2.5 GAS DELIVERY SYSTEM

The Bi-Fuel System utilizes a vacuum-based gas control system, whereby changes in combustion airflow result in a corresponding change of gas flow to the engine. The gas is supplied to the engine with the use of an air-gas mixing device (mixer) installed upstream of the turbocharger compressor inlet.

2.5.1 AIR-GAS MIXER

The Air-Gas Mixer (**AGM**) blends engine intake-air with an appropriate quantity of natural gas as required for combustion. The **AGM** is installed upstream of the turbocharger compressor inlet and downstream of the engine air cleaner housing. The GTI Air-Gas Mixer is a fixed-venturi design and does not utilize a moveable air-throttle.

Air entering the **AGM** is diverted around a gas diffuser section, causing a turbulent, low pressure area to form. This low pressure area draws natural gas from the diffuser section gas reservoir through a radial pattern of precision machined gas outlet orifices. Gas is introduced into the turbulent airflow area immediately downstream of the gas diffuser section, allowing for a high degree of mixing action of the two media with a **MINIMUM** of airflow restriction.

The CAD-designed **AGM** is constructed of aerospace quality materials that have been CNC-machined and then assembled using a state-of-art welding process. The **AGM** is mil-spec anodized for surface hardness and corrosion protection. The GTI Air-Gas Mixer comes standard in **3", 4", 5", 6", 7" and 10" O.D. (76, 102, 127, 152, 178 and 254mm O.D.)**.



2.5.2 GASTRAIN

2.5.2.1 – GASTRAIN, SERIES I, II, III, AND IV

The Bi-Fuel System requires precise regulation and control of the fuel supply gas. In order to ensure nominal operation, the Bi-Fuel System is supplied with a specialized “gas train” consisting of a gas filter, zero pressure gas regulator and electrically activated gas solenoid valve. The gas train is designed to accept low-pressure supply gas in the range of **1-5psig (108.2-135.8kPa)** and supply regulated gas to the engine at slightly negative pressure.



FILTER

The gas filter is designed to protect the gas train and engine from particulate contaminants that may be present in the gas stream. The filter element is made of random laid nonwoven polypropylene fabric with a stainless steel support frame and a pore width of approximately **50** microns. The filter housing is a cast aluminum two-piece design with NBR seals. Dust, chips and rust as well as other gas-accompanying particulate contaminants are retained by the random laid non-woven fabric. If the storage capacity of the filter is exceeded or if there is an excessive pressure differential, the filter will lose its protective function. The filter element should be changed a **MINIMUM** of once per year or anytime the pressure differential has increased **100%** compared to a new filter or when pressure differential exceeds **.15psig (10mbar)**. The gas filter is supplied with pressure taps upstream and downstream of filter element in order to measure the pressure differential across the filter.

Note: Gas train components are not compatible with gas temperatures above 140°F (60°C).

Note: The gas filter is not intended for primary gas filtration. Supply gas must be fuel-grade quality.

ZERO GOVERNOR REGULATOR

The **ZG** regulator consists of a cast aluminum housing containing working diaphragms, an adjustable pressure set-point spring and a pre-loaded counter spring. The regulator utilizes NBR diaphragms and seals and is suitable for methane-based gasses up to **0.1 vol.% H₂S** (dry). Not recommended for use with gasses that would corrode aluminum, steel, or other non-ferrous metals such as brass. The regulator operates according to the differential pressure between the inlet port and outlet port in order to maintain the set delivery pressure. The regulator detects changes in engine vacuum (at the outlet port) as engine load increases or decreases and adjusts gas flow rate in order to maintain the set outlet pressure. The **ZG** regulator supplies gas to the engine at approximately atmospheric pressure.

DUAL MODULAR SOLENOID VALVE, SERIES I, II, III, AND IV

The Dual Modular Valve (**DMV**) is a DC powered, normally closed, two stage gas control valve. The **DMV** consists of a cast aluminum housing containing two independent “normally-closed” valves. The **DMV** utilizes NBR diaphragms and seals and is suitable for methane-based gasses up to **0.1 vol.% H₂S** (dry). Not recommended for use with gasses that would corrode aluminum, steel, or other non-ferrous metals such as brass. The **DMV** is supplied **24** volts DC from the Bi-Fuel Control Panel via a dedicated wiring harness. When the **DMV** is energized, i.e., when Bi-Fuel mode is activated, the first stage opens instantly while the second stage slowly ramps to the **100%** open position (approximately **30** seconds for second stage to reach the fully open position). The slow-opening action of the **DMV** allows the Bi-Fuel System to maintain engine stability during transition to Bi-Fuel mode. When de-energized, both stages of the **DMV** valve close instantly, resulting in immediate transition of the engine to **100%** diesel mode.

2.5.2.2 – VALVE-REGULATOR-FILTER BLOCK, SERIES A

The Bi-Fuel System requires precise regulation and control of the fuel supply gas. In order to ensure nominal operation, the **Series A** system utilizes a multi-function Valve-Regulator-Filter Block assembly (**VRF**) which serves the same function as the gas train in the larger systems. This assembly is equipped with a replaceable particulate filter to prevent dust, chips and rust as well as other gas-accompanying particulate contaminants from entering the operational portion of the device. The element should be inspected on a regular basis and replaced as necessary or at least once a year.

VRF Block is a DC-powered, normally-closed, two valve, two-way gas control valve suitable for methane based gases up to **0.1 vol.% H₂S** (dry). It is not recommended for use with gasses that would corrode aluminum, steel, or other non-ferrous metals such as brass. The solenoid valves are supplied **12 volts DC** from the Bi-Fuel Control Panel via a dedicated wiring harness. When energized, the Bi-Fuel mode is activated. When de-energized, the engine is immediately switched to **100%** diesel mode.



Series A VRF Block Assembly

NOTE: The Valve-Regulator-Filter (VRF) block assembly requires 12 volts DC.

2.5.2.2 – VALVE-REGULATOR-FILTER BLOCK, **SERIES A** (continued)

The **VRF** also serves as a zero governor regulator with an adjustable pressure set-point spring and a preload counter spring. The regulator operates according to the differential pressure between the inlet port and outlet port in order to maintain the set delivery pressure. The regulator detects changes in engine vacuum (at the outlet port) as engine load increases or decreases and adjusts gas flow rate in order to maintain the set outlet pressure. The regulator supplies gas to the engine at approximately atmospheric pressure.

2.5.3 GAS POWER VALVE

The Gas Power Valve (**GPV**) is a proprietary flow metering device that allows for precise adjustment of gas flow to the engine. The **GPV** works in conjunction with the **ZG** regulator and Air-Gas Mixer to control the amount of gas supplied to the engine for a given engine load. The **GPV** is constructed of aerospace quality materials that have been CNC machined and then assembled using a state-of-the-art welding process. The finished gas power valve is then mil-spec anodized for surface hardness and corrosion protection. The **GPV** uses a needle and seat type flow adjustment comprised of an adjustable threaded gas screw and seat. Once set, the gas screw position sets a fixed and limiting orifice inside the power valve body, thereby controlling the maximum flow of gas available across the engine load range. As engine load changes, there is a corresponding change in engine vacuum level. The **ZG** regulator responds to this change in vacuum by supplying more (increasing engine load) or less (decreasing engine load) gas in order to maintain the set output flow. The **GPV**, installed between the **ZG** regulator and the Air-Gas Mixer, governs the maximum amount of gas that can flow to the engine for the given vacuum demand. By using the adjustable gas screw, the operator is able to set the desired gas-diesel ratio. For engines requiring two Air-Gas Mixers, a “**Dual GPV**” is provided which contains three separate gas screws (primary gas screw and two secondary gas screws for adjustment of gas flow to each engine bank). For engines requiring one Air-Gas Mixer, a “**Single GPV**” is supplied with one gas adjusting screw. The gas power valve is incorporated in the **3"**, **4"** and **5"** air-gas mixers.



Dual Gas Power Valve

Single Gas Power Valve

2.6 CONTROLS AND MONITORING

Note: Refer to operating manuals GPN0100 OM, GPN1000 OM OR GPN2010 OM for instructions on operation and adjustment of the GCN0100, DE-1510 or DE-3010 Engine Controller.

The Bi-Fuel System is supplied with an electronic control panel that monitors and displays critical engine and Bi-Fuel System parameters. Based on input from various sensors and user programmed limits, the panel will activate or deactivate Bi-Fuel mode as required. Depending on the model of Bi-Fuel System, the control panel will include either a **CGN** control instrument (**GPN0100**), **DE-1510** primary controller (**GPN1000**) or a **DE-3010** controller (**GPN2010V**). The panel is supplied with all necessary engine and gas train sensors and harnesses. Sensors are connected to the panel via pre-fabricated, labeled and loomed wiring harnesses. Harnesses are shipped loose and wires must be landed on the terminal strip of the **GPN** control panel by the installing technician. The controllers are dedicated microprocessor-based systems designed to sense specific analog and digital input points to control and monitor the GTI Bi-Fuel natural gas fumigation system for diesel engines. Serial communications provide an interface to PC's, PLC's, and modems, for remote communication if desired. A backlit LCD display shows system status, programmed controller parameters and channel labels. A front mounted keypad serves as the user interface. The controls provide for the natural gas fueling off/on control function and for an optional closed loop automatic control function to optimize the amount of natural gas substitution of diesel fuel under varying modes of operation. Additionally, the controllers provide for remote data acquisition and supervisory control in a compact, low cost package dedicated to natural gas substitution on industrial diesel engine applications.



**GTI Bi-Fuel Electronic Control Panels
GPN0100, GPN1000, GPN2010V**

2.6.1 GPN1000 AND GPN2010V CONTROL PANELS FOR USE WITH GAS TRAIN : SERIES I-A, II, III, AND IV

The **GPN1000** and **GPN2010V** series are configurable for various applications using a PC (personal computer) and the supplied **DE** terminal program and contain a non-volatile memory to store the setup. Engine parameters monitored include exhaust gas temperature (**EGT**), manifold air pressure (**MAP**), manifold air temperature (**MAT**), engine vacuum (**VAC**), and engine vibration (**VIB**). Other parameters monitored include gas supply pressure (**GSP**) to the GTI gas train, as well as **ZG** regulator output pressure (**ROP**) at the gas train outlet. The panel is provided with LED indicator lights that provide a quick visual status of the Bi-Fuel System. If a fault is detected by the control system, Bi-Fuel operation is suspended and the engine is reverted to **100%** diesel operation.

CONTROL LOGIC

Programmed setpoints are defined as either **CONTROL** or **SAFETY SHUTDOWN**. Manifold air pressure (**MAP**) is the only **CONTROL** setpoint and is used to determine the engine load “window” in which Bi-Fuel operation will be allowed. The control panel uses the engine **MAP** data to determine engine load and the user is able to program **MINIMUM** and **MAXIMUM MAP** values, where the **MINIMUM** value sets the “light-load limit” for Bi-Fuel operation and the **MAXIMUM** value sets the “high-load limit” for Bi-Fuel operation.

All other monitored parameters are defined as **SAFETY SHUTDOWN**; in the event a programmed limit is exceeded, the control panel will deactivate Bi-Fuel mode and return the engine to **100%** diesel fuel operation.

All control panel models feature a “Bi-Fuel Inhibit” feature which prevents operation in Bi-Fuel mode until an external contact is closed. The external contact is typically a relay indicating an “engine run” or “breaker closed” condition. This feature allows the control panel to remain energized at all times (in order to display any fault messages after engine shutdown), while preventing the possibility of gas flow while the engine is not running.

PARAMETERS MONITORED BY THE CONTROL PANEL:

EXHAUST GAS TEMPERATURE (EGT)

The control panel monitors **EGT** to protect against excessive combustion temperatures while operating in Bi-Fuel mode. The user programs a **MAXIMUM** allowable value for **EGT**. Depending on Bi-Fuel System model, the panel comes standard with **1** or **2** channels of **EGT** monitoring. **EGT** is typically monitored for each bank of cylinders (one **EGT** channel for in-line engines, two **EGT** channels for V engines). If additional temperature monitoring is required, a **GPN 22XX** series panel may be required. **EGT** is displayed in either Celsius or Fahrenheit units and is monitored using a “K” type thermocouple. In the event **EGT** exceeds the programmed safety limit, the control panel automatically switches the engine fuel mode to **100%** diesel operation.

Note: The GPN1000-12 is a 12-volt system that operates with the VRF block (refer to Section 2.5.2.2). Control logic is as described in Section 2.6.1, except that no ROP switch is used.

Note: Violation of a SAFETY SHUTDOWN setpoint will not result in shutdown of the engine, only a change in fuel mode. The control panel changes engine fuel mode by energizing or de-energizing the DMV gas valve. In the event of a safety shutdown, the DE controller will display the cause of the shutdown and activate a red LED indicator on the GPN control panel face.

MANIFOLD AIR TEMPERATURE (MAT)

MAT is monitored by the control panel to protect against excessive temperature increases that could lead to a knocking condition in Bi-Fuel mode. The user programs a **MAXIMUM** allowable value for **MAT**. Depending on Bi-Fuel System model, the panel comes standard with **1** to **4** channels of **MAT** monitoring for each discrete manifold or aftercooler. **MAT** is displayed in either Celsius or Fahrenheit units and is monitored using a “K” type thermocouple. In the event **MAT** exceeds the programmed limit value, the control panel automatically switches the engine fuel mode to **100%** diesel operation.

MANIFOLD AIR PRESSURE (MAP)

MAP is monitored by the control panel to determine engine load. The user programs **MINIMUM** and **MAXIMUM** values for **MAP**. The **MINIMUM** value sets the **MINIMUM** engine load limit for Bi-Fuel operation and the **MAXIMUM** value sets the **MAXIMUM** load limit for Bi-Fuel operation. Once these values are programmed, the engine will only operate in Bi-Fuel mode when the load is **ABOVE** the programmed **MINIMUM** value and **BELOW** the programmed **MAXIMUM** value. Depending on Bi-Fuel System model, the control panel comes standard with **1** to **4** channels of **MAP** monitoring for each discrete intake-air manifold. **MAP** is displayed in either **psig** or **kPa** units and is monitored using a pressure transducer.

ENGINE VACUUM (VAC)

VAC is monitored by the control panel to protect against excessive engine air-filter restriction. Excessive air-filter restriction and associated high **VAC** levels can result in an over fueling condition in Bi-Fuel mode. Depending on Bi-Fuel System model, the panel comes standard with **1** or **2** channels of **VAC** monitoring for each discrete engine air-intake manifold. In the event **VAC** exceeds the programmed limit value, the control panel automatically switches the engine fuel mode to **100%** diesel operation. The user programs a **MINIMUM** value for engine **VAC**. **VAC** is displayed in either **psig** or **kPa** units and is monitored using a pressure transducer.

ENGINE VIBRATION (VIB)

VIB is monitored by the control panel to protect against excessive engine vibration. Excessive engine vibration during Bi-Fuel operation may indicate a knocking condition or other combustion related abnormality. **VIB** monitoring is optional on **Series I** and **Series II** control panels. **Series III** and **Series IV** Bi-Fuel Systems come standard with **1** or **2** channels of **VIB**. **VIB** is typically monitored for each bank of cylinders (one **VIB** channel for in-line engines, two **VIB** channels for V engines). The user programs a **MAXIMUM** allowable value for **VIB**. In the event **VIB** exceeds the programmed limit value, the control panel automatically switches the engine fuel mode to **100%** diesel operation. **VIB** is displayed in either inches per second (**IPS**) or millimeters per second (**MPS**) units and is monitored using a vibration transducer.

GAS SUPPLY PRESSURE (GSP)

GSP is monitored by the control panel in order to protect against variations in gas supply pressure. The user programs **MINIMUM** and **MAXIMUM** values for **GSP**. The **GPN1000** and **GPN2010** series Bi-Fuel System control panels come standard with one channel of **GSP** monitoring. **GSP** is monitored at the inlet to the GTI-supplied gas train. In the event **GSP** exceeds the programmed limit values, the control panel automatically switches the engine fuel mode to **100%** diesel operation. **GSP** is displayed in either **psig** or **kPa** values and is monitored using a pressure transducer.

REGULATOR OUTPUT PRESSURE (ROP)

ROP is monitored by the control panel to protect against possible misadjustment or failure of the **ZG** gas regulator. In the event **ROP** exceeds approximately **+1** inch w.c. (**0.25kPa**), the control panel automatically switches the engine fuel mode to **100%** diesel fuel. **ROP** is monitored with a gas pressure switch located on the **DMV** valve.

2.6.2 GPN0100-12 CONTROL PANEL USED WITH VRF BLOCK: SERIES A-E

The **GPN0100-12** system is configurable for various applications using the front mounted keypad and contains a non-volatile memory to store the setup. Serial communications provide an interface to PC's, PLC's, and modems, for remote communication if desired. A backlit LCD character display shows system status, programmed controller parameters and channel labels in a compact, low cost package dedicated to natural gas substitution on industrial diesel engine applications. Engine parameters monitored include exhaust gas temperature (**EGT**) and manifold air pressure (**MAP**). If a fault is detected by the control system, Bi-Fuel operation is suspended and the engine is reverted to **100%** diesel operation.

CONTROL LOGIC

High and low programmed setpoints are provided for Control and **SAFETY SHUTDOWN**. Manifold air pressure (**MAP**) is used as a **CONTROL** setpoint and is used to determine the engine load “window” in which Bi-Fuel operation will be allowed. The control panel uses the engine **MAP** data to determine engine load and the user is able to program minimum and maximum **MAP** values, where the minimum value sets the “light-load limit” for Bi-Fuel operation and the maximum value sets the “high-load limit” for Bi-Fuel operation.

Exhaust gas temperature (**EGT**) serves as a **SAFETY SHUTDOWN**; in the event a programmed limit is exceeded, the control panel will deactivate Bi-Fuel mode and return the engine to 100% diesel fuel operation.

The **GPN0100-12** control panel is also equipped with a “Bi-Fuel Inhibit” feature which prevents operation in Bi-Fuel mode until an external contact is closed. The external contact is typically a relay indicating an “engine run” or “breaker closed” condition. This feature allows the control panel to remain energized at all times (in order to display any fault messages after engine shutdown), while preventing the possibility of gas flow while the engine is not running.

Note: The GPN0100-12 controller is a 12-volt system that operates the VRF block (GGT0311-12 and GGT0411-12) kits.

The GPN0100 controller is a 24-volt system that operates the GGT0501B gas train kits. Refer to Section 4.2.2. It uses the control logic described in Section 2.6.2.

The GPN1000-12 controller is a 12-volt system that operates the GGT0411-12 gas train. See Section 4.2.1.

Upon power up, a user adjustable fuel delay countdown timer is activated. The controller prevents activation of the Bi-Fuel mode while this timer is active. Once expired, if the Bi-Fuel inhibit input is closed and no setpoints are violated, the controller will activate Bi-Fuel mode by powering the solenoid valve on the **VRF** block.

Note: EGT is a latching fault that requires manual reset by the user before Bi-Fuel function can be resorted. This is accomplished by cycling the controller power.

PARAMETERS MONITORED BY THE CONTROL PANEL:

EXHAUST GAS TEMPERATURE (EGT)

The control panel monitors **EGT** to protect against excessive combustion temperatures while operating in Bi-Fuel mode. The user programs a **MAXIMUM** allowable value for **EGT**. The exhaust gas temperature is displayed in either Celsius or Fahrenheit units and is monitored using a “K” type thermocouple. In the event **EGT** exceeds the programmed safety limit, the control panel automatically switches the engine fuel mode to **100%** diesel operation.

MANIFOLD AIR PRESSURE (MAP)

MAP is monitored by the control panel to determine engine load. The user programs **MINIMUM** and **MAXIMUM** values for **MAP**. The minimum value sets the minimum engine load limit for Bi-Fuel operation and the maximum value sets the maximum load limit for Bi-Fuel operation. Once these values are programmed, the engine will only operate in Bi-Fuel mode when the load is **ABOVE** the programmed **MINIMUM** value and **BELOW** the programmed **MAXIMUM** value. **MAP** is displayed in either **psig** or **kPa** units and is monitored using a pressure transducer.

2.7 AIR-FUEL RATIO/LEL

Operation in Bi-Fuel mode does not appreciably change engine air-fuel ratio. At the maximum allowable gas substitution rates (**70%**), the gas concentration in the intake air is typically less than **3.0%** by volume, which is substantially below the **5.0%** Lower Explosive Limit (**LEL**) of methane. Due to the lean condition of the air-gas charge, the possibility of ignition in the engine air-intake system due to backfire or other causes is minimized.

2.8 COMBUSTION PROCESS

Combustion in Bi-Fuel mode follows the normal compression-ignition (CI) sequence. The air-gas mixture is admitted to the combustion chamber through the OEM intake valve and then compressed during the compression cycle. The high auto-ignition temperature of the lean air-gas mixture prevents ignition of the charge until the diesel injector is activated. The injected diesel fuel provides the necessary ignition source for the air-gas mixture which then combusts at a similar speed and pressure compared to **100%** diesel operation. Although the injected diesel fuel acts as an ignition source for the air-gas mixture, it is also providing a portion of the total energy needed for combustion, based on the set gas-diesel ratio.

2.9 ENGINE GOVERNING

The Bi-Fuel System allows the original engine governing system to control engine speed. As gas is introduced to the engine, the governor detects a slight increase in engine rpm, as the engine temporarily has more fuel than needed for the current load condition. In order to maintain the pre-set speed, the governor quickly adjusts the position of the diesel fuel “rack”, thereby maintaining engine speed and allowing the substitution of natural gas. No interface or tie-in is required between the Bi-Fuel System and the engine governor. The Bi-Fuel System is compatible with **ISOCHRONOUS** electro-mechanical and hydro-mechanical governors as well as electronic injection-based governing systems.

Note: Engine must be equipped with an ISOCHRONOUS governor to operate properly with the GTI Bi-Fuel system.

Engine Parameter	100% Diesel Mode	Bi-Fuel @ 70% Gas
Power	1000HP	1000HP
Speed	1800RPM	1800RPM
Diesel Rack Position (%)	90%	27%

Comparison of Engine Governing: Bi-Fuel vs. 100% Diesel

2.10 ENGINE PERFORMANCE

As shown below, conversion to GTI Bi-Fuel typically results in similar performance levels in terms of engine stability, response and block load capability:

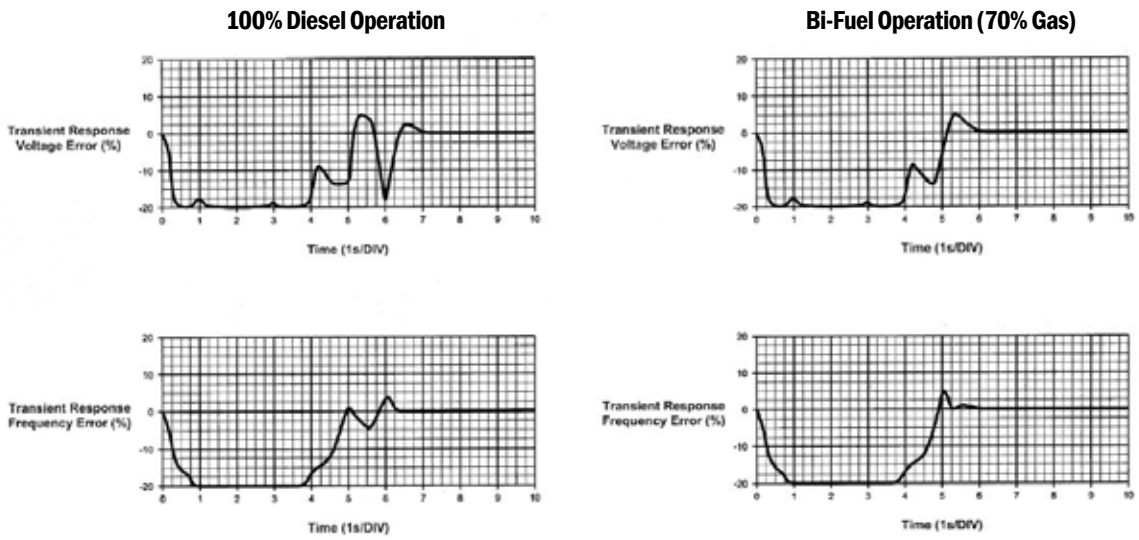

Typical Responses to 100% Block Load Application

2.11 GAS-DIESEL RATIO

Gas composition, engine load factor, charge-air temperature and ambient conditions (temperature and altitude) govern the upper limit of gas substitution in most cases. Gas ratio is typically limited by the knock limit of the air-gas mixture at a particular engine load. In general terms, high quality gas and moderate engine loads (up to **80%** of stand-by rating), will typically yield gas ratios between **65-70%**. Lower quality natural gas, high engine loads, high charge-air temperatures and high altitude (or a combination of these factors) will typically limit gas ratio to between **50-65%**.

2.12 ENGINE LUBE OIL

Unless otherwise indicated by gas composition, no changes in engine lube oil specification are required for Bi-Fuel operation. Natural gas burns with **MINIMUM** particulate residues so that engine oil may be kept cleaner during Bi-Fuel operation. This can possibly lead to longer average intervals between lube oil and oil filter changes and extended periods between engine overhauls. No changes should be made to the OEM's recommended service intervals without complete engine oil and wear analysis and consultation with the OEM.

2.13 TIME AND MANPOWER REQUIREMENTS FOR CONVERSION

Conversion time will depend on the size and complexity of the application. Generally, one to two days will be required for smaller engines, while larger engines might require two to three days. In either case, manpower required is usually limited to **1-2** technicians.

2.14 ENGINE OPERATING TEMPERATURES

Engine heat rejection rates while operating in Bi-Fuel mode are largely similar to **100%** diesel performance. Engine exhaust gas temperature, coolant temperature, oil temperature and manifold air temperature levels remain within the limits set by the engine manufacturer.

2.15 ENGINE EFFICIENCY

Because the Bi-Fuel System utilizes a low restriction air-gas mixing device and maintains the excess-air operation of the diesel engine, net fuel efficiency (specific fuel consumption) is normally equivalent to **100%** diesel operation. For each unit of diesel fuel displaced during Bi-Fuel operation, a calorically equivalent unit of natural gas will be needed to maintain engine power.

2.16 BI-FUEL EMISSIONS

Bi-Fuel operation will typically reduce production of nitrogen oxides, sulfur oxides, reactive hydrocarbons, carbon dioxide and particulates. Exhaust opacity levels (visual emissions) are also typically reduced.

2.17 ENGINE WARRANTY

Installation of the Bi-Fuel System does not generally impact factory engine warranties. Because the engine is not modified from the original design, OEM's typically take the position that while they will not be responsible for Bi-Fuel related failures, the full force and effect of their warranty will remain valid after conversion to Bi-Fuel.

2.18 BI-FUEL SYSTEM WARRANTY

Primary components of the Bi-Fuel System including mixers, electronic controllers and gas train components are covered by a two year limited warranty. Electronic sensors, switches and thermocouples are covered by a one year limited warranty. Please reference GTI's Product Warranty statement for details.

3.0 GAS SUPPLY

3.1 GENERAL

The term “natural gas” generally refers to a combustible, gaseous mixture of simple hydrocarbon (**HC**) compounds, usually found in deep underground reservoirs. Natural gas is primarily composed of methane (**CH₄/C₁**), but can also contain small amounts of other gases, including ethane, propane, butane and other compounds. At room temperature and pressure, methane is a colorless and odorless gas. Gas distributors/processors typically add odorant to the natural gas in order to alert operators to gas leaks. Natural gas is typically distributed via pipelines, but may also be transferred/stored in the form of **LNG** (liquid natural gas) or **CNG** (compressed natural gas).

3.2 GAS VARIATION

Pipeline gas typically has little variation in quality and composition on a day to day basis and is normally made up of **>90%** methane. Gas composition is an important factor for Bi-Fuel operation as the combustion characteristics of methane differ substantially from heavier hydrocarbon compounds. **Generally, as the methane content of the fuel decreases and the heavy-HC content increases, the combustion characteristics of the fuel will change and may require a lower substitution percentage of natural gas.** While the heating value of pipeline quality natural gas will vary somewhat, it is generally in the range of **1000Btu/scf** or **37.25MJ/m³**. A comparison of summer and winter gas composition should be made to determine any seasonal variation in gas composition.

3.3 NON-PIPELINE GASES

Other methane-based gases can be utilized with the Bi-Fuel System such as wellhead gas and bio-gas. When utilizing gases other than pipeline quality, the following factors must be considered:

- Methane content
- Heavy hydrocarbon content
- Heating value
- Inert gas content
- Moisture content
- Caustics
- Particulates

For reasons explained above, it is important to determine the base composition of the fuel gas as well as the possible range of composition prior to installation of the Bi-Fuel System. Wellhead gas often consists of a greater fraction of heavy HC's, and in some cases, may have less than **50%** methane. The installer should be wary of so called “hot gas” which, due to high HC concentrations, can have heat rates in excess of **1200Btu/scf (44MJ/m³)**.

Note: If the fuel has a heavy hydrocarbon concentration of >20% in the normal gas stream, or alternately, can have periodic “slugs” of heavy-hydrocarbons exceeding >20%, it may be necessary to decrease the gas substitution percentage and/or de-rate the engine during Bi-Fuel operation.

3.4 FILTRATION

For non-pipeline gases (and some lower quality pipeline gases), it is important to determine if sufficient filtering means have been incorporated in the gas supply line such that particulate and liquid contents in the fuel are kept to a level approximating fuel grade standards. GTI recommends, at a minimum, the use of a high quality, coalescing type filter for all non-pipeline applications. It is also important to determine what caustic compounds, if any, are present in the fuel which may potentially cause harm to the engine and/or gas components of the Bi-Fuel System. Additional filtration or treatment may be required in order to protect against engine damage. For bio-gas fuels derived from landfills, waste treatment facilities, etc., it is not uncommon to see high levels of caustic compounds such as sulphur, which when combined with small amounts of water can form damaging acids. It is possible to filter-out these types of contaminants, and filtration should be utilized if caustic compounds are present in the fuel.

3.5 FLOW AND PRESSURE

For purposes of sizing gas supply piping and/or specifying gas regulators and meters, the following general guidelines are recommended:

FLOW: For estimating gas flow requirements for electrical power generation applications, assume a maximum flow requirement of **8 standard cubic feet per hour per kWe (scfh/kWe)** or **0.23 cubic meter per kWe (m³/kWe)**. For example, a **1500kWe** generator will require maximum gas flow of **12,000 (1500 x 8) scfh** or **345 m³/hr. (0.23 x 1500)**.

For pump or compressor applications (or other direct drive systems), assume a gas flow rate of **6.4scfh/h.p.** or **0.18m³/h.p.** For example, a compressor drive engine operating at **600h.p.** will require a gas flow of **3,840scfh (600 x 6.4)** or **108m³/hr.**

The guidelines outlined above assume gas flow based on the highest allowable gas substitution ratio. Actual gas flows may be significantly less than calculated depending on maximum possible gas ratio for a given application.

Gas flow estimates are based on pipeline grade natural gas with typical heating values. For estimating gas flow requirements for non-pipeline gasses, please contact GTI.

PRESSURE: The GTI gas train has been designed to work with a regulated, low pressure gas supply of between **1 and 5psig (108.2 to 135.7kPa)**. For optimum performance, GTI recommends a working pressure of **3psig±1psig (122kPa±108.2kPa)**, with a maximum deviation of **<0.3psig (<103.4kPa)** from the set pressure in all operating modes.

Note: It is the responsibility of the end-user to ensure that the gas supplied to the engine is “fuel grade quality” and sufficiently treated to prevent engine damage.

Note: It is critical that the gas supply system be designed and installed to provide the required steady state pressure at the full gas load of the facility (including all GTI-equipped gensets operating at full load) free of pressure fluctuations and oscillations at the gas train inlet. GTI accepts no responsibility for design of the gas supply system upstream of the inlet to the gas train filter.

Note: to convert from KVA to kWe, multiply KVA value by 0.8.

Note: Rapid deviation or oscillation of supply gas pressure in Bi-Fuel mode indicates a malfunctioning or improperly specified primary regulator. Rapid changes in gas supply pressure can result in engine instability during Bi-Fuel operation.

4.0 INSTALLATION

4.1 AIR-GAS MIXER INSTALLATION



WARNING:

FAILURE TO FOLLOW THESE INSTRUCTIONS MAY RESULT IN FIRE, EXPLOSION, OR IMPROPER ENGINE OPERATION CAUSING PROPERTY DAMAGE, INJURY, OR LOSS OF LIFE. PERSONNEL WHO LACK APPROPRIATE TRAINING SHOULD NOT ATTEMPT TO INSTALL THE AIR-GAS MIXER.



WARNING:

INSTALLATION OF THE AIR-GAS MIXER MAY REQUIRE REMOVAL OF THE TURBO-COMPRESSOR AIR SUPPLY CONDUIT. OPERATION OF THE ENGINE WITH AN EXPOSED TURBO-COMPRESSOR INLET REPRESENTS AN EXTREME HAZARD TO NEARBY PERSONNEL. ENGINE SHOULD BE IN "MANUAL STOP" MODE WHILE COMPRESSOR INLET IS EXPOSED.



CAUTION:

NO MODIFICATIONS MAY BE MADE TO THE AIR-GAS MIXER. UNAUTHORIZED MODIFICATIONS TO THE AIR-GAS MIXER MAY RESULT IN IMPROPER OPERATION OF THE ENGINE AND/OR DAMAGE TO THE CONVERTED ENGINE.



CAUTION:

BEFORE INSTALLATION OF THE MIXER, AN OPERATIONAL CHECK OF THE AIR INTAKE MANIFOLD SYSTEM OF THE ENGINE, INCLUDING CHARGE-AIR COOLING SYSTEM, SHOULD BE COMPLETED TO VERIFY THAT NO LEAKS EXIST.

NOTE: ANY LEAKS IN THE INTAKE MANIFOLD SYSTEM WILL RESULT IN THE RELEASE OF A FLAMMABLE AIR-GAS MIXTURE.

Note: The AGM is marked to indicate direction of air flow.

Note: Installation of the AGM should not significantly alter the routing or geometry of the original engine air intake system. Ensure AGM will not make contact with any metal surfaces, as engine vibration will cause chafing and eventual failure of the AGM.

The Air-Gas Mixer (**AGM**) is installed in the engine air intake system between the air filter housing and turbocharger compressor inlet. The **AGM** is typically installed using either the existing "hump hose" connectors in the intake conduit, or with hump hose connectors or adaptors supplied with the Bi-Fuel System (or locally sourced).

The **AGM** is unidirectional and will not function if installed incorrectly. Install the **AGM** with the pointed diffuser "cone" facing towards the engine air filter and the diffuser exhaust orifices facing the turbocharger compressor inlet.

For engines with two or more air intake systems, it will generally be necessary to install one (**1**) **AGM** for each discrete air filter assembly. If properly specified, the Bi-Fuel System should be supplied with the appropriate quantity of Air-Gas Mixers for the engine to be converted. If unsure of number of Air-Gas Mixers required for a particular application, please contact your supplier or GTI for technical support.

The **AGM** may be installed at any angle as required by the geometry of the original air intake system.

Before installation of the **AGM**, determine the approximate location where the gas train and Gas Power Valve will be installed in order to determine any possible routing conflicts of the flexible gas delivery line. Relocation of the air filter housing(s) may be required in order to provide space for the **AGM**. Before disassembly of the intake conduit, appropriate measurements should be taken to determine final location of **AGM** and/or air filter housing.

GTI BI-FUEL® SYSTEM

Install **AGM** using appropriately rated hump hoses and t-bolt type clamps. Prior to final tightening of hump hose clamps, rotate **AGM** so that the threaded gas inlet nipple is facing in the general direction of where the gas train will be installed. Tighten hump hose clamps. Verify that the hump hoses have formed an airtight seal around the mixer.



GTI Bi-Fuel Air/Gas Mixer

Note: The AGM is installed downstream of the engine air filter(s). Leaks will result in unfiltered air entering the engine, possibly leading to premature engine wear or failure.



Typical GTI Bi-Fuel System Mixer Installation

All **AGM** models (except 3" and 4") come standard with a 1.5" JIC male threaded gas inlet nipple. The **AGM** is connected to the Gas Power Valve using a flexible fuel delivery hose. The flexible hose assembly requires 1.5" female JIC swivel fittings at each end in order to connect to the **AGM** and **GPV**. Reusable JIC swivel fittings and flex hose are supplied as optional items in the Bi-Fuel kit; please contact your supplier if you do not have these items.

The 3" and 4" **AGM** models are equipped with a 1" hose barb end. The supplied 1" hose slips over this barb and is secured with a hose clamp.

Note: Care must be taken when threading the JIC female swivel connector onto the male AGM nipple to avoid cross threading. Gas delivery hose must be protected from chafing against engine surfaces or brackets and must be protected from direct heat sources such as exhaust manifolds, using appropriate shielding or protective heat wrap.

4.2 GAS TRAIN ASSEMBLY AND INSTALLATION SERIES I, II, III, IV



WARNING:

FAILURE TO FOLLOW THESE INSTRUCTIONS MAY RESULT IN IMPROPER ENGINE OPERATION, ENGINE DAMAGE, FIRE OR LOSS OF LIFE. PERSONNEL WHO LACK APPROPRIATE TRAINING SHOULD NOT ATTEMPT TO INSTALL THE GAS TRAIN. USE OF UNAUTHORIZED OR MODIFIED GAS TRAIN COMPONENTS MAY LEAD TO IMPROPER OPERATION OF THE BI-FUEL SYSTEM AND/OR PERSONAL INJURY OR DEATH TO OPERATORS AND NEARBY PERSONNEL.



WARNING:

NOMINAL GAS SUPPLY PRESSURE IS 3PSIG \pm 1PSIG (122KPA \pm 108.2KPA). DO NOT EXCEED 5PSIG (135.7KPA) SUPPLY PRESSURE TO GAS TRAIN.



CAUTION:

THE GAS POWER VALVE IS NOT DESIGNED OR INTENDED AS A GAS SHUTOFF DEVICE. GAS FLOW ACROSS THE VALVE CAN OCCUR EVEN WITH GAS SCREW(S) SET TO THE MINIMUM POSITION.

4.2.1 ASSEMBLY OF THREADED GAS TRAINS – Series A

Series A gas train components are supplied with threaded connections. Use appropriate thread sealing compound and/or Teflon[®] tape for assembly. Use care to avoid getting pipe sealing compounds inside gas train components. Use caution as Teflon[®] tape and/or thread sealant can allow for excessive tightening due to decreased friction. Careful assembly is required to prevent cross threading which can cause damage to the gas train components.

During assembly of threaded components, apply gentle wrench pressure to avoid possible fracture of components or stripping of threads. The **GPV** should not be excessively tightened into the adaptor or reducer bushing. In most cases, the **GPV** can be adequately tightened by hand.



Series A VRF Block Assembly

Series A Valve-Regulator-Filter (VRF) Block Assembly: Assemble the **Series A VRF** block by installing the adapter flanges provided (**G11021**) on both the inlet and outlet ports of the block (**GSV010-12**). Be sure that the O-rings over the inlet and outlet ports are properly in place during installation of the flanges. Install the 1 inch hose adapter (**G11028**) by threading it into the discharge flange. Use appropriate thread sealing compound and/or Teflon[®] tape for assembly. Use care to avoid getting pipe sealing compounds inside gas train components. Use caution as Teflon[®] tape and/or thread sealant can allow for excessive tightening due to decreased friction. Careful assembly is required to prevent cross threading which can cause damage to the thread adapter. During assembly of threaded components, apply gentle wrench pressure to avoid possible fracture of components or stripping of threads.

4.2.2 Series I Gas Train Assembly: Assemble the **Series I** gas train using the **2"** NPT pipe nipples provided. The **GPV (P/N GPV1015AAT)** supplied with the **Series I** gas train has a **1.5"** male NPT inlet; the **GPV** is connected to the **DMV** outlet using the supplied **2"** NPT x **1.5"** NPT reducer bushing.

Note: Recommended maximum torque for Series I gas train components is 1190 lb-in.

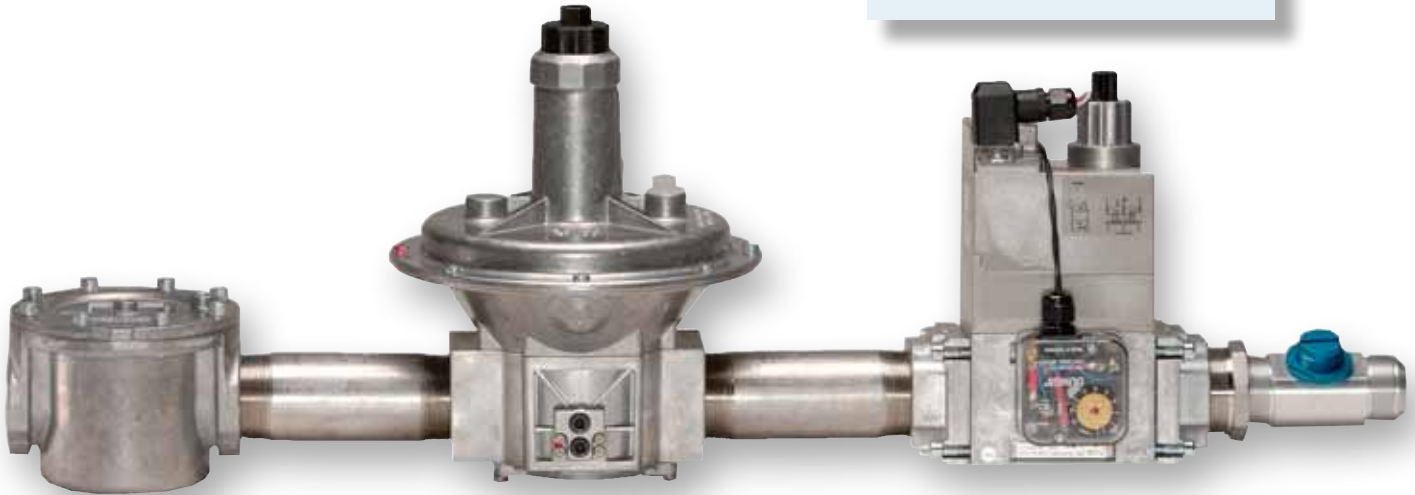

Series I Gas Train Assembly

4.2.3 ASSEMBLY OF FLANGED GAS TRAINS – Series II, III AND IV

Series II, III and IV Bi-Fuel Systems are supplied with flanged gas train components. **Series II and III** gas train components come standard with **DN65 (65mm/2.56")**, 4-bolt flanges. **Series IV** gas train components come standard with **DN80 (80mm/3.1")**, 8-bolt flanges.

Series II and III gas trains are supplied with either an “in-line” **GPV (P/N GPV1015AAT)** or a “dual” **GPV (P/N GPV2025AAT)**. **Series II and III** gas trains are supplied with two **DN65 x 2.5"** NPT female flange adaptors (**P/N G11007**); one of the flange adaptors is used to mate the **GPV** to the **DMV** outlet port. The second flange adaptor may be used at the gas train inlet in order to provide a threaded connection to the gas supply piping. **Series II** and **III** gas trains supplied with the “in-line” **GPV** include a **2.5"** NPT x **1.5"** NPT bushing adaptor to allow mating of the **GPV** to the flange adaptor.

Series IV gas trains are supplied with either a “dual”, **3.0"** NPT male **GPV (P/N GPV2030AAT)** or an “in-line, **3.0"** NPT male **GPV (P/N GPV1030AAT)**. **Series IV** gas trains are supplied with two **DN80x3.0"** NPT female flange adaptors (**P/N G11008**); one of the flange adaptors is used to mate the **GPV** to the **DMV** outlet port. The second flange adaptor may be used at the gas train inlet in order to provide a threaded connection to the gas supply piping.

Flanged gas trains come standard with the required hardware and seals for assembly. Flanges should be tightened using an alternating pattern to assure even tightening across the flange face; do not over tighten bolts.

Note: recommended maximum torque for flange bolts is 443 lb-in.



Typical Flanged Gas Train Assembly

4.2.4 MOUNTING OF GASTRAIN

Gas trains may be mounted on or off the engine/generator skid. Before choosing a location for the gas train, consideration should be given to routing and required length of flexible fuel hoses (to Air-Gas Mixers), vibration isolation, proximity to heat sources and connection to gas supply piping. In addition, the installation of the gas train should not inhibit routine maintenance of the engine or generator. Gas trains should be mounted according to accepted industry standards, using appropriately rated bracketing materials or supports. If mounted above the engine (suspended from ceiling), gas train must be supported using “unistrut” type brackets in a “trapeze” configuration. Gas trains (**Series I, II, III and IV**) must be supported at a minimum of two locations, preferably with even weight distribution between support points.

Note: Cantilever mounting of the gas trains is not approved. Ambient temperature range for all gas trains is -40°F to +150°F (40°C to +60°C).

After installation of gas train is completed, the complete assembly must be leak tested using an industry standard leak detection fluid (“Snoop” or equivalent); **ALL LEAKS MUST BE FIXED PRIOR TO OPERATING ENGINE IN BI-FUEL MODE.**



Typical GTI Bi-Fuel Gas Train Mounting Options: “Trapeze” Method (left), and “Bottom” Method (right)

4.3 CONTROL PANEL INSTALLATION



WARNING:

WARNING! INSTALLATION AND WIRING OF BI-FUEL CONTROL PANEL MAY REQUIRE CONNECTION TO ENGINE/GENERATOR CONTROLS HOUSING. CARE SHOULD BE TAKEN TO AVOID PHYSICAL CONTACT WITH POTENTIALLY DEADLY HIGH VOLTAGE SOURCES LOCATED WITHIN ENGINE/GENERATOR CONTROL HOUSINGS.

Controls for all **GPN** models are housed in a weatherproof fiberglass enclosure rated **NEMA 4X**. The **GPN1000** and **GPN2010** series panels are equipped with LED indicators mounted on front and a **DE Power/Terminal Module** mounted inner panel. The **GPN0100** is equipped with a custom **GCN** controller with all status indications provided on the instrument-mounted display.

The control panel can be installed directly on the engine/generator skid or on an adjacent wall. In some cases, the control panel may be suspended from the ceiling using “unistrut” type support structure. Location of panel should allow for easy access to the control keypad and manual on-off switch as well as good visibility of panel LED indicator lights (**GPN1000** and **GPN2010** series panels) and LCD displays. Consideration should also be given to the various distances to each engine/gas train sensor and routing requirements of the sensor wiring harnesses. The control panel should not be mounted in close proximity to hot engine surfaces such as exhaust manifolds or mufflers. If the control panel is mounted on the engine/generator skid, suitable vibration isolators should be used to protect the control panel from excessive vibration.

The **GPN0100-12 AND GPN1000-12** panels require a **12VDC** power supply (rated at **15AMPS**). The **GPN0100**, **GPN1000** and **GPN2010** series panels require a **24VDC** power supply (rated at **5AMPS**). Both panels also provide DC power to the gas control solenoid valve during Bi-Fuel operation. In most applications, the panel is connected to a continuous DC power supply. This is done so that logged fault messages are not lost after engine shutdown. In order to prevent the possibility of the control panel activating the gas solenoid valve when the engine is not running, Bi-Fuel inhibit terminals are provided for a separate “engine run” or “breaker closed” permissive. When this feature is used, the control panel cannot activate Bi-Fuel operation without a contact closure at these terminals.

4.4 SENSOR INSTALLATION (SEE PAGE 42)

4.4.1 EXHAUST GAS TEMPERATURE (EGT) THERMOCOUPLE (P/N TCK0420-SS OR TCK0430-SS)

The **EGT** thermocouple is installed in the engine exhaust system. The thermocouple should be mounted in a position where it is exposed to exhaust gasses from all cylinders of the particular bank. Typical mounting locations include the exhaust manifold, turbocharger exhaust outlet or exhaust collector pipe. In all cases, the **EGT** thermocouple should be installed as close to the cylinders as possible and should not be installed downstream of the exhaust silencer. Depending on model of Bi-Fuel System, up to four separate **EGT** thermocouples may be installed. Each **EGT** thermocouple is supplied with a bore-through type adaptor with $\frac{1}{8}$ " male NPT threads.

Note: For detailed information on DE and GCN controllers, please see forms GPN0100 OM, GPN1000 OM, and GPN2010 OM.

Note: Sections 4.4.2, 4.4.4, 4.4.5, 4.4.6 and 4.4.7 do not apply to the GPN0100 and GPN0100-12 panels.

Section 4.4.7 does not apply to the GPN1000-12 panel.



4.4.2 MANIFOLD AIR TEMPERATURE (MAT) THERMOCOUPLE (P/N TCK0420-SS OR TCK0430-SS)

The **MAT** thermocouple is installed in the engine air-intake system. The thermocouple should be mounted **AFTER** the turbo-compressor, in a position where it can sense the temperature of the combustion air. For engines with charge-air cooling systems, the sensor should be installed **AFTER** the aftercooler so that the temperature of the air entering the cylinders can be measured. Depending on model of Bi-Fuel System and configuration of engine, up to four separate **MAT** thermocouples may be installed. Each **MAT** thermocouple is supplied with a bore-through type adaptor consisting of a 1/8" male NPT thread and compression fitting.

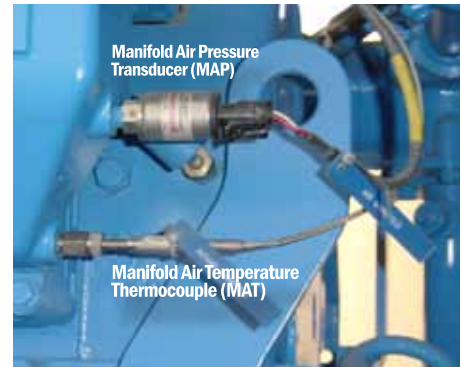

Note: Care must be taken not to confuse the MAP and GSP transducers, as the transducers are visually identical except for the part numbers.

4.4.3 MANIFOLD AIR PRESSURE MAP TRANSDUCER (P/N 691201-50)

The **MAP** transducer is installed downstream of the turbocharger outlet (pressure side) in order to sense manifold air pressure (turbo boost). Depending on Bi-Fuel System model and engine configuration, one to four **MAP** transducers may be installed. For engines with charge air cooling systems, the **MAP** transducer should be installed **AFTER** the cooling circuit in order to decrease the operating temperature of the transducer. Remote-mounting of the **MAP** transducer will be required if operating temperatures will exceed **200°F (93°C)**.

4.4.4 ENGINE VACUUM (VAC) TRANSDUCER (P/N 691206-50)

The **VAC** transducer measures the vacuum signal in the air intake system between the air cleaner and turbocharger compressor inlet. The **VAC** transducer is installed in a 1/8" female NPT port provided in the barrel wall of the Air-Gas Mixer (**AGM**). Depending on model of Bi-Fuel System and configuration of engine, up to two separate **VAC** transducers may be installed. Each **VAC** transducer is supplied with an 1/8" male NPT connection.



4.4.5 VIBRATION (VIB) TRANSDUCER (P/N 691205)

The **VIB** transducer is mounted on the engine deck or cylinder head using the supplied heat-sink adaptor. The heat sink adaptor is supplied with a $\frac{3}{8}$ "-16 thread stud for mounting to engine. Terminate the **VIB** wiring harness (2 wires) at the terminal connector block provided on the **VIB** transducer (the top of **VIB** transducer must be removed to access terminal block) using the provided cable gland and heat shrink tubing shown.

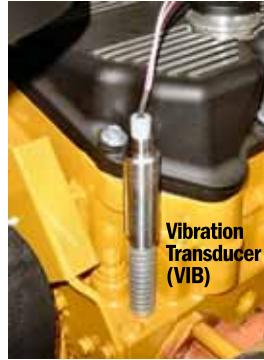

Note: Vibration transducers are included in Series III and Series IV kits. They are recommended, but optional on Series I and Series II kits.

If possible, the **VIB** transducer should be mounted vertically (in the same plane as the engine cylinders). For single **VIB** installations, mount the transducer on either end of engine. For dual **VIB** installations, mount the transducers on opposite corners of engine (diagonal).

4.4.6 GAS SUPPLY PRESSURE (GSP) TRANSDUCER (P/N 691201-15)

For **Series II, III and IV** kits, the **GSP** transducer is mounted in one of the available **OUTLET** pressure ports located on the gas filter. Pressure drop across the filter may be determined by comparing **GSP** (as displayed on Bi-Fuel control panel) to the upstream supply pressure (as measured with a mechanical pressure gauge). Adaptor fitting (P/N 610879) and gasket (P/N 610880) are provided in the Panel Accessory Kit for mounting of the **GSP** transducer. For **Series I** kits, install **GSP** transducer upstream of the GTI gas train using a $\frac{1}{8}$ " NPT female pressure tap (provided by others). Adaptor fitting (P/N 610879) and gasket (P/N 610880) are provided in the Panel Accessory Kit for mounting of the **GSP** transducer.



4.4.7 REGULATOR OUTPUT PRESSURE (ROP) SWITCH

The **ROP** pressure switch is mounted in the gas train **AFTER** the gas regulator in a position where it can sense gas supply pressure to the engine (vacuum). The **ROP** switch comes with a rubber O-ring seal and is **ONLY** to be installed using the designated port on the **DMV** valve body. A cable gland (P/N 610756, included with the control panel accessory package) should be installed on the **ROP** switch to insure adequate wire strain relief.

On **Series I** gas trains (**DMV-DLE** series solenoids) the **ROP** switch is mounted using Pressure Switch Adapter to port **3**, as shown.

On **Series II through IV** gas trains (**DMV-D11** series solenoids) the **ROP** switch is installed on port **5**, as shown.

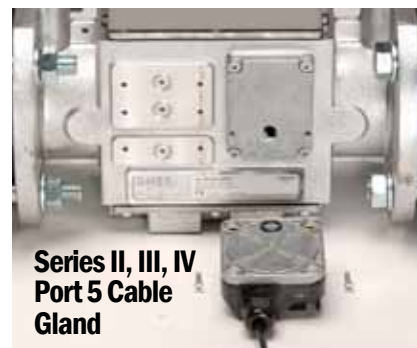

4.5 WIRING

Wiring harnesses from the control panel to left bank, right bank (if applicable), fuel train, and power source are furnished with the GTI Bi-Fuel kit.

REFER TO THE APPROPRIATE OPERATING MANUAL, GPN0100 OM, GPN1000 OM OR GPN2010 OM FOR DETAILED WIRING INFORMATION.

Harnesses should be installed in the proper control panel entrance hole and properly terminated within the control panel. They should be routed to the locations of the sensors and power source, using care to avoid routing near excessively hot surfaces or surfaces which will vibrate and chafe the harnesses.

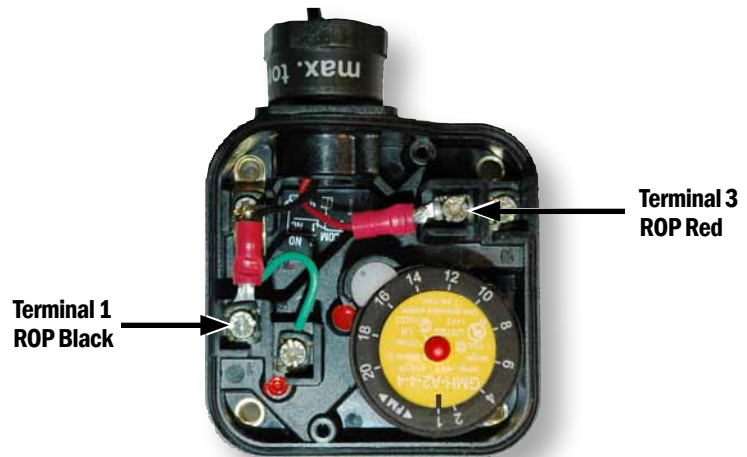

FUEL HARNESS TO ROP CONNECTIONS



DMV SOLENOID CONNECTIONS:

A cable gland (P/N 610756, included with the control panel accessory package) should be installed on the solenoid valve connector to insure adequate wire strain relief.

5.0 ENGINE SETUP AND OPERATION



WARNING: FAILURE TO FOLLOW THESE INSTRUCTIONS MAY RESULT IN IMPROPER ENGINE OPERATION AND/OR ENGINE DAMAGE. BI-FUEL SETUP IS RESTRICTED TO QUALIFIED PERSONNEL ONLY.

5.1 GENERAL CONSIDERATIONS

5.1.1 ENGINE CONDITION: Prior to commencing the Bi-Fuel setup process, a thorough check of engine operation on **100%** diesel fuel should be performed. This check should include all major engine systems (cooling, lubrication, fuel, charge-air cooling, air intake, safety, etc.) for proper operation and condition. It is recommended that a load test of the engine be performed to verify that the engine performs according to specifications. All outstanding maintenance and/or performance items should be addressed prior to running the engine in Bi-Fuel mode.

5.1.2 ESTIMATING GAS-DIESEL RATIO: Since most engines do not have fuel flow meters installed to show actual consumption of diesel fuel, GTI has developed a reliable method of adjusting gas-diesel ratio based on information from the engine fuel governing system. All constant speed diesel engines utilize some form of fuel control system which varies diesel fuel flow in response to load change, in order to maintain the desired engine speed. Control methods commonly used include mechanical fuel racks, fuel rail pressure regulators or electronic injection. Regardless of the type of fuel control system used, the basic operating theory is the same; diesel flow is controlled in a linear manner from **0%** flow (engine off) to **100%** flow (full load). For a given load condition, the governor will adjust between the **0%** and **100%** fuel limits in order to maintain engine speed; this value is generally referred to as “rack position” or “fuel position”. Other things being equal, for a given engine load there will be a definite rack position and therefore a definitive diesel fuel flow.

During Bi-Fuel operation at a given load, the governor will retard the rack position (i.e., diesel fuel flow) relative to the amount of gas that is being supplied to the engine, in order to maintain the set speed. Since this retarded rack position can be correlated to a specific engine load (and vice versa), the diesel fuel flow, and therefore the gas-diesel ratio, can be calculated with good accuracy. In practice, a “reference load” is calculated at which the diesel fuel flow and rack position are equal to the diesel portion of the target gas-diesel ratio. For example, if a **60%** gas mixture is desired for a genset operating at **1200kWe**, the reference load would be **480kWe** ($1200 \times .40 = 480\text{kWe}$). The engine is then loaded to **480kWe** and the rack position is noted. The engine is then loaded to **1200kWe** and the gas ratio adjusted such that the rack position (i.e., diesel fuel flow) is equivalent to the **480kWe** load level.

At this point, **the engine would be producing 1200 kWe while using the diesel fuel required to make 480kWe**, i.e., the balance is being made up with the gas, and the engine is operating at a fuel ratio of approximately **60%** gas and **40%** diesel fuel.

Note: Engine must be equipped with an ISOCHRONOUS governor to operate properly with the GTI Bi-Fuel system.

Note: For electronic diesel engines using ECU control of injection timing and duration, DO NOT USE COMPUTED FUEL FLOW AS REFERENCE. The fuel flow data from the ECU is derived from calculations based on various engine data (not from fuel flow meters) and may not be accurate while engine is operating in Bi-Fuel mode. "Injector duration" and/or "fuel position" data will be accurate during both diesel and Bi-Fuel modes.

5.1.3 MEASUREMENT OF ENGINE POWER: For electrical generator applications, engine power may be measured in electric kilowatts (**kWe**) and/or Amps. For pump or compressor applications, it may be necessary to calculate engine load based on **MAP** (manifold air pressure) or pump/compressor load.

5.1.4 METHODS OF MEASURING RACK POSITION: In order to adjust the Bi-Fuel system to achieve the desired gas-diesel ratio, it will be necessary to measure the "rack position" or "fuel position" of the diesel injection system at a given engine load. The following techniques can be used:

Measurement of control signal from governor to actuator (electronic governors such as Woodard 2301). This can be taken using a digital multimeter installed in series between the governor control module ("ACT" contact) and actuator. This value is typically measured in milliamps (mA).

Measurement of "fuel position" or "injector duration" (electronic diesel engines such as Caterpillar B Series). This typically requires the use of proprietary engine diagnostic software (provided by engine manufacturer) and either a laptop computer or hand-held diagnostic tool.

Measurement of physical position of diesel fuel rack (rack %). Depending on design of the fuel system, it may be possible to measure rack travel directly, using calipers, index, etc. Since total rack travel from **0%** to **100%** is typically a short distance, this measurement must be made with a high degree of accuracy.

5.2 ESTABLISHING TARGET BI-FUEL OPERATING VALUES

5.2.1 TARGET BI-FUEL GAS-DIESEL RATIO: The gas substitution that is possible varies depending on gas quality, engine design, engine model and condition, engine load factor, charge air temperature (aftercooling), and ambient conditions (altitude and temperature), but should never exceed **70%**, even under the most ideal conditions. In general, high quality gas (**over 95% CH4**), combined with moderate engine power levels and low temperature aftercooling will typically yield gas ratios in the **60%** to **70%** range, although there are factors that can still limit this value to much lower levels. Lower quality gas, combined with high manifold air temperature (**MAT**) and/or higher engine loads, will typically result in gas substitution closer to **50% or lower. The final gas ratio will be determined during the commissioning process** and may be higher or lower than the target value, based on knock limits, engine exhaust temperatures, and/or other operating factors.

KNOCK LIMIT: In most applications, engine knock (detonation) will be the limiting factor in determining **MAXIMUM** gas ratio. In most cases, short duration knock will not cause harm to the engine, however, extended operation in a knocking condition may result in engine damage or failure. A knocking condition can be diagnosed both audibly and using the Bi-Fuel System vibration sensor (**VIB**) data. Data from the engine vibration sensors (if installed) should be monitored closely during the setup procedure to confirm proper engine operation. If knocking is detected during Bi-Fuel operation, the engine should be rapidly switched to **100%** diesel operation. To prevent recurrence of knocking, a reduction in gas ratio and/or a reduction in engine load will be required.

5.2.2 TARGET BI-FUEL MAXIMUM LOAD RATING: Engines converted to GTI Bi-Fuel are typically utilized for peak shaving, prime power, co-generation, or other high use applications. It is important for the installing technician to understand the power rating system used for most high-speed diesel engines, and the associated duty-cycles applicable to each. Most manufacturers of high speed (**1200–1800rpm**) diesel engines and generator sets publish stand-by, prime and continuous ratings. The stand-by rating is reserved for emergency operation only and represents the highest HP or kW level that can be sustained for a limited period of time. In most applications, the stand-by rating will not be used for Bi-Fuel operation. The prime rating typically allows for unlimited hours of use, with a variable load, up to the prime rated output. The continuous rating is the most conservative rating, and is reserved for unlimited hours at a constant load. In general, Bi-Fuel mode is reserved for operations at or below the prime rating of the machine. The higher the number of hours of intended use, and the more constant the load rate, the more conservative the rating should be. For baseload type operations, GTI recommends a rating of **80%** of continuous for Bi-Fuel mode.

5.3 SETUP PROCEDURE

Before proceeding with the setup procedure, the installing technician should be familiar with operation of the Bi-Fuel Electronic Control Panel and controller programming procedures. Refer to the Operating Manual (**GPN0100 OM, GPN1000 OM OR GPN2010 OM**) for instructions on operation of the **GPN0100, GPN1000** or **GPN2010V** model Bi-Fuel Control Panels.

The **GPN1000** panel (**DE-1510** Controller) is shipped with a standard program which assumes a vibration sensor will be in use. If no vibration sensor will be used, the Controller must be re-programmed, or the control and shutdown setpoint adjusted so that the lack of a sensor will have no effect. Programming instructions, which also allow the user to switch from English to Metric units, are contained within the “Programming” section of the Controller Operating Manuals referenced above. Terminal program software is supplied with the Bi-Fuel System and requires use of a standard Personal Computer (PC) as the interface device. **SEE SECTION 6.0 FOR A GUIDE THAT SHOWS WHICH PROGRAM IS APPLICABLE FOR A PARTICULAR BI-FUEL SYSTEM.** Program load can be checked by sequencing through the channels on the Display unit (**DE-1510 and DE-3010**) and verifying that sensor data is being displayed and that all appropriate channels are being displayed. The **GPN0100** panels do not require terminal software. All configuration is done via the **GCN** keypad. All **GPN** panels are shipped with factory default settings for all control and safety setpoints. **GPN1000** and **GPN2010** series panels are also shipped with a factory default configuration. This configuration can be changed using the appropriate terminal software. A complete listing of the default settings and configurations is available in the applicable **GPN** manual.

Note: The engine-generator is not de-rated by the Bi-Fuel System. Higher engine power levels are still available to the user (above the Bi-Fuel rating) as the Bi-Fuel System will automatically transition the engine to 100% diesel mode if the power level rises above the limit programmed in the electronic control panel. GTI has seen a willingness on the part of some users to operate their engines at load levels inconsistent with long term engine durability. It must be stressed to the operator that high speed diesel engines will incur significant maintenance expenses if operated at high load levels for long periods, regardless of whether operating on Bi-Fuel or 100% diesel mode.



IMPORTANT:

The GPN0100 and GPN0100-12 panels utilize only Manifold Air Pressure (MAP) and Exhaust Gas Temperature (EGT) sensors. References in the following procedures to VIB, MAT, GSP, VAC, and ROP apply to the GPN1000 and GPN2010V panels only.

For GPN0100 and GPN0100-12 panels, it is recommended that the customer have external means of measuring the gas supply pressure before the VRF block in order to verify proper gas supply pressure.

The following procedure offers a general guideline to Bi-Fuel System setup and commissioning.

**DIRECT ANY QUESTIONS TO YOUR SUPPLIER
OR GTI CUSTOMER SUPPORT: (330) 545-4045 M-F, 8 AM TO 5 PM (EST)
OR EMAIL: SALES@GTI-ALTRONIC.COM.**

*Note: For collecting baseline engine data, the manual gas valve **MUST** be in the **OFF** position and the GTI panel **MUST** be in the **MANUAL STOP** mode (GPN1000 and GPN2010V). The GPN0100 panel **MUST** be in **BI-FUEL INHIBIT** mode.*

1. Collect Baseline Engine Data

TURN THE MANUAL GAS VALVE TO THE OFF POSITION. For GPN1000 and GPN2010V panels, place the panel in **MANUAL STOP**. For GPN0100 panels, place the panel in **BI-FUEL INHIBIT** mode. This can be accomplished by removing the Bi-Fuel inhibit jumper from the terminals inside the panel or disconnecting from the end device being used to activate/deactivate the Bi-Fuel inhibit feature. Any time the Bi-Fuel inhibit terminals are open, the **BI-FUEL INHIBIT** mode is activated. Turn the Bi-Fuel control panel power switch to the **ON** position, load the engine or generator to the target maximum Bi-Fuel rating, and run for approximately **20** minutes to allow for stabilization of temperatures. Record the following data using the Bi-Fuel Control Panel and engine/generator control panel:

All Control Panel Models

- exhaust gas temperature (EGT)
- manifold air pressure (MAP)
- ambient air temperature
- engine speed
- frequency (genset)
- engine coolant temperature
- engine oil pressure
- engine oil temperature
- governor control signal, fuel position, rack position, etc.

GPN1000 and GPN2010V Panels

- manifold air temperature (MAT)
- engine vibration (VIB)
- ENGINE VACCUUM (VAC)

2. Calculate “Reference Load”

Multiply load used in **STEP 1** above by the diesel portion of target gas-diesel fuel ratio. The reference load fuel position data will be used as a guideline during the gas adjustment process.

Example:

Target Bi-Fuel load: 1000 kWe
Target gas ratio: 60%
Target diesel ratio: 40%
Reference load: 400 kWe (1000 kWe x .40)

3. Record Diesel Rack Position Data

Reduce engine load to the reference value and record diesel rack position data using one of the methods outlined above.

Example:

Reference load: 400 kWe
Governor ACT signal: 900 mA

4. Reduce Engine Load to 0%

5. Adjust Gas Power Valve to Baseline Setting

Fully close **GPV** gas adjusting screw(s). Using permanent marker or pencil, index gas adjustment screw(s) so that the number of turns open (from fully closed position) can be determined. After each adjustment of the **GPV**, ensure that the locking ring is sufficiently tight to prevent unwanted movement of the gas adjusting screw.

For “dual” power valve applications: it may be necessary to adjust secondary gas screws to keep both engine banks balanced for **MAP**, **EGT** and **VIB**. Bank to bank gas trim adjustments will likely be required for engines utilizing discrete (separate) air-intake manifolds and/or aftercoolers; gas trim adjustments should be limited to less than **1/8-turn** at a time.

For “single” GPV models: open the gas adjusting screw one **(1)** full turn from the fully closed position.

For “dual” GPV models: open the primary gas adjusting screw one **(1)** full turn from the fully closed position. Open the secondary gas adjusting screws to four **(4)** full turns each from the fully closed position.

6. Set Initial MAP “Control Setpoints” in Bi-Fuel Control Panel

Set **MAP “Low”** and **MAP “High”** Control Setpoints to **5psig (135.7kPa)** and **40psig (376.9kPa)** respectively. **MAP** Control Setpoints will be re-adjusted at the conclusion of the setup procedure.

7. Set EGT, MAT, VIB, VAC and GSP “Control Setpoints”

Adjust the Control Setpoints for **EGT**, **MAT**, **VIB**, **VAC** and **GSP** channels to the **MINIMUM** and **MAXIMUM** values (low and high setpoint span values). This will prevent unwanted “Control” shutdowns of the Bi-Fuel System.

Note: all setpoints must be reviewed for correct values based on the application.

NEVER assume that the default values are adequate or will result in a safe condition.

Note: DE-1510 Terminal 13 (+ to -) and DE-3010 Terminal 13 (+ to -).

8. Set Initial “Safety Setpoints” in Bi-Fuel Control Panel

With the Bi-Fuel Control Panel in “manual stop”, set the **EGT**, **MAT** and **VIB** “high” limits to **105%** of the values recorded in **STEP 1**. Set the **EGT**, **MAT** and **VIB** “low” limits to the **MINIMUM** allowable value. For **VAC**, set the “low” limit value to **-0.2psig (100kPa)** of the value recorded in **STEP 1**. Set the **VAC** “high”, limit to the **MAXIMUM** allowable value. Set **GSP** “low” limit value to **1psig (108.2kPa)** and **GSP** “high” limit value to **4psig (128.9kPa)**.

9. Check “Bi-Fuel Inhibit” Contact

Check Bi-Fuel Inhibit contact. If this feature is not being used, confirm that jumper has been installed.

10. Verify Gas Supply Pressure (GSP)

Slowly turn manual gas valve to the **ON** position and observe the gas pressure displayed on the DE screen. **GSP** should be between **3 ±1psig (122.0 ±6.1kPa)** as a starting pressure. If **GSP** is below **2psig** or above **4psig**, adjust supply pressure regulator as required.

11. Verify ZG Regulator Output Pressure (ROP) Setpoint

Confirm **ROP** switch setpoint set to **+1** inch w.c. (**Series I-IV**). Note that the **ROP** switch is not used with the **GPN1000-12** panel on the **SERIES A-A** kit.

12. Initialize ZG Regulator

SERIES I, II, III, IV, AND I-E (GPN0100, 24VDC)

Set the **ZG** regulator to the minimum pressure setting by rotating adjustment screw fully counterclockwise. The spring supplied with the **ZG** regulator is color-coded brown, and has an effective pressure range of **-1.0" w.c. to +1.6" w.c.** If using a manometer, **ZG** regulator output pressure should be approximately **-0.5" w.c. to 0.0" w.c.** with the engine running in Bi-Fuel mode.

SERIES A-E

Access to make **VRF** output pressure adjustments can be made from either side of the assembly. Use a flat head screwdriver to slide open the access door. Pressure output adjustments are made using a **NO. 2.5** (metric) Allen wrench.

Set the **ZG** feature of the **VRF** to the minimum pressure setting by rotating the adjustment screw accordingly. The effective range of the device is **-1.0" w.c. to +1.0" w.c.** If using a manometer, the output pressure should be approximately **-0.5" w.c. to 0.0" w.c.** with the engine running in Bi-Fuel mode.

13. Verify Engine Governor “Gain” Setting

Governor gain should be set at approximately **70%-80%** for optimal Bi-Fuel operation. Higher gain settings may cause engine instability during transition from diesel mode to Bi-Fuel mode and vice-versa.

14. Reset Bi-Fuel Control Panel – Verify Control Status

With engine at **0%** load, manually reset the Bi-Fuel Control Panel (GPN1000 and GPN2010V). For GPN0100, de-activate the **Bi-Fuel Inhibit** mode (install jumper or connect to external device). Verify that Bi-Fuel Controller is in Control Shutdown mode (both red and green status LED's are off for the GPN1000 and GPN2010V, **BI-FUEL OFF** showing on top line of display on GPN0100).

15. Verify Proper Operation of Bi-Fuel System – Part Load

Load engine to approximately **50%** of the target Bi-Fuel rating. Verify that the Bi-Fuel Control Panel display indicates **Bi-Fuel On** and that the green **RUN** LED is illuminated on GPN1000 and GPN2010V panels. The engine is now operating in Bi-Fuel mode using a **MINIMUM** quantity of gas. Monitor Bi-Fuel System parameters and engine behavior for irregularities. Confirm that **GSP** is holding within **0.3psig (103.4kPa)**. If **GSP** shows oscillation of more than **0.3psig**, the primary supply regulator must be adjusted as required.

16. Increase Engine Load to Target Bi-Fuel Rating

17. Adjust Gas Ratio to 50% of target value

Example:

Target gas ratio: 70%

50% value: 35%

Adjust **GPV** as necessary to increase gas ratio to approximately **50%** of target value using the following method:



CAUTION:

AS GAS RATIO IS INCREASED, IT IS THE RESPONSIBILITY OF THE INSTALLING TECHNICIAN TO CONSTANTLY MONITOR ENGINE PERFORMANCE AND BEHAVIOR USING DATA PROVIDED BY THE BI-FUEL CONTROL PANEL AND/OR ENGINE/GENERATOR CONTROL PANEL AS WELL AS AUDIBLE ENGINE NOISE.

FOR SINGLE GPV MODEL – increase (open) gas screw position using $\frac{1}{4}$ to $\frac{1}{2}$ -turn increments. After each adjustment, rack position should be re-checked to confirm governor response. Continue to make small incremental adjustments to the gas power valve screw until the rack position data indicates that the initial gas ratio of **50%** of target value has been reached.

FOR DUAL GPV MODEL – increase (open) primary gas screw position using $\frac{1}{4}$ to $\frac{1}{2}$ -turn increments. After each adjustment, rack position should be re-checked to confirm governor response. If continued adjustments to the primary gas screw results in little or no rack position change, open secondary gas screws $\frac{1}{2}$ -turn each, and re-check rack position. Continue to make small incremental adjustments to the primary gas screw and/or secondary gas screws (as required) until the rack position data indicates that the initial gas ratio of **50%** of target value has been reached. Confirm bank to bank balance for **EGT**, **MAP** and **VIB**; adjust secondary gas screws as required.

Note: Bi-Fuel Control Panel is in Control Shutdown mode due to low MAP, i.e., at 0% load, MAP should be under the control setpoint of 5psig (135.7kPa).

Note: ZG regulator pressure output may be adjusted during Bi-Fuel setup procedure if required. Do not attempt to set ZG regulator pressure in static condition; engine must be drawing gas for accurate pressure setting. The ZG regulator should only be adjusted if Gas Power Valve adjustments fail to increase gas ratio. Maximum allowable pressure at ZG regulator outlet is 0.0 inch w.c. (with the engine operating in Bi-Fuel mode). Do not set ZG regulator above 0.0 inch w.c. (positive pressure).

18. Collect Engine & Bi-Fuel System Data

Collect engine data as per **STEP 1**. Confirm **GSP** is holding within **0.3psig (103.4kPa)** tolerance. Verify **VIB** and **EGT** values are within normal limits. Listen carefully to the engine to confirm that no audible knocking is occurring. Confirm proper engine operation before proceeding to next step.

19. Increase gas ratio to 70% of target value

Example:

Target gas ratio: 70%

70% value: 49%

Adjust **GPV** as necessary to increase gas ratio to approximately **70%** of target value using the following method:



CAUTION:

AS GAS RATIO IS INCREASED, IT IS THE RESPONSIBILITY OF THE INSTALLING TECHNICIAN TO CONSTANTLY MONITOR ENGINE PERFORMANCE AND BEHAVIOR USING DATA PROVIDED BY THE BI-FUEL CONTROL PANEL AND/OR ENGINE/GENERATOR CONTROL PANEL AS WELL AS AUDIBLE ENGINE NOISE.

FOR SINGLE GPV MODEL – increase (open) gas screw position using $\frac{1}{4}$ to $\frac{1}{2}$ -turn increments. After each adjustment, rack position should be re-checked to confirm governor response. Continue to make small incremental adjustments to the gas power valve screw until the rack position data indicates that a gas ratio of **70%** of target value has been reached.

FOR DUAL GPV MODEL – increase (open) primary gas screw position using $\frac{1}{4}$ to $\frac{1}{2}$ -turn increments. After each adjustment, rack position should be re-checked to confirm governor response. If continued adjustments to the primary gas screw results in little or no rack position change, open secondary gas screws $\frac{1}{2}$ -turn each, and re-check rack position. Continue to make small incremental adjustments to the primary gas screw and/or secondary gas screws (as required) until the rack position data indicates that the initial gas ratio of **70%** of target value has been reached. Confirm bank balance for **EGT, MAP** and **VIB**; adjust secondary gas screws as required.

20. Collect Engine & Bi-Fuel System Data

Collect engine data as per **STEP 1**. Confirm **GSP** is holding within **0.3psig (2.0kPa)** tolerance. Verify **VIB** and **EGT** values are within normal limits. Listen carefully to the engine to confirm that no audible knocking is occurring. Confirm proper engine operation before proceeding to next step.

21. Increase gas ratio to 100% of target value

Adjust gas power valve to increase gas ratio to **100%** of target value using the following method:

**CAUTION:**

AS GAS RATIO IS INCREASED, IT IS THE RESPONSIBILITY OF THE INSTALLING TECHNICIAN TO CONSTANTLY MONITOR ENGINE PERFORMANCE AND BEHAVIOR USING DATA PROVIDED BY THE BI-FUEL CONTROL PANEL AND/OR ENGINE/GENERATOR CONTROL PANEL AS WELL AS AUDIBLE ENGINE NOISE.

FOR SINGLE GPV MODEL – increase (open) gas screw position using $\frac{1}{4}$ to $\frac{1}{2}$ -turn increments. After each adjustment, rack position should be re-checked to confirm governor response. Continue to make small incremental adjustments to the gas power valve screw until the rack position data indicates that the target gas ratio has been reached.

FOR DUAL GPV MODEL – increase (open) primary gas screw position using $\frac{1}{4}$ to $\frac{1}{2}$ -turn increments. After each adjustment, rack position should be re-checked to confirm governor response. If continued adjustments to the primary gas screw results in little or no rack position change, open secondary gas screws $\frac{1}{2}$ -turn each, and re-check rack position. Continue to make small incremental adjustments to the primary gas screw and/or secondary gas screws (as required) until the rack position data indicates that the target gas ratio has been reached. Confirm bank to bank balance for **EGT**, **MAP** and **VIB**; adjust secondary gas screws as required.

Note: It may not be possible to reach desired gas ratio at target Bi-Fuel rating. If target gas ratio cannot be reached safely, it will be necessary to decrease gas ratio or decrease target Bi-Fuel load rating.

22. Collect Engine & Bi-Fuel System Data

Collect engine data as per **STEP 1**. Confirm **GSP** is holding within **0.3psig (103.4kPa)** tolerance. Listen carefully to the engine to confirm that no audible knocking is occurring. Confirm proper engine operation before proceeding to next step.

23. Operational Test

Operate engine in Bi-Fuel mode using typical load conditions. Monitor Bi-Fuel System Safety and Control parameters. Minimum test duration of **2-3** hours is recommended. If possible, test engine under variable load conditions to confirm nominal performance in Bi-Fuel mode.

24. Confirm Minimum Load Setpoint

Reduce engine load to approximately **10%** of the Bi-Fuel maximum load rating. Monitor engine stability, genset frequency and voltage, etc. Minimum load for Bi-Fuel operation may be set in a range from **0%** load to **10%**, or as otherwise required by operational considerations. When final light load setpoint is established, note **MAP** value.

25. Finalize MAP Control Setpoints

Set **MAP** “Low” and **MAP** “High” Control Setpoints to define Bi-Fuel load window. Set **MAP** low setpoint to value established in step **24**. Set **MAP** high setpoint to **+5psig (135.7kPa)** above value recorded at maximum Bi-Fuel load, as per step **20**.

26. Finalize Safety Shutdown Setpoints (EGT, MAT, VIB)

Set **EGT**, **MAT** and **VIB** Safety Shutdown Setpoints (high) based on a comparison of values recorded in **STEPS 1** and **22** (**100%** diesel operation vs. Bi-Fuel operation). Final setpoints are at the discretion of the installing technician, however, GTI recommends that **EGT**, **MAT**, and **VIB** values should be within **+10%** of diesel baseline. Take notice that Safety Setpoints are set slightly above the desired limit in order to prevent nuisance shutdowns in Bi-Fuel mode.

27. Finalize Safety Shutdown Setpoints (GSP)

Set **GSP** “high” and “low” Safety Shutdown Setpoints to within **±0.5psig (±104.7kPa)** of the desired setpoint, or as otherwise dictated by the stability of the gas supply pressure.

28. Secure GPV and ZG Regulator Settings

Secure locking nuts on **GPV** gas adjustment screws (do not over tighten). Use of lead seals or other tamper proofing materials is recommended to prevent unauthorized adjustment of the **GPV** or **ZG** regulator.

29. Record Bi-Fuel Settings

Record Bi-Fuel Control Panel settings for **EGT**, **MAP**, **MAT**, **VIB** and **GSP** channels for future reference. Record final position of **GPV** gas adjustment screws (number of turns open).

30. Record Engine Data and Start Date

Record engine make, model, serial number and rating. Record date of Bi-Fuel start-up.

31. Complete GTI Bi-Fuel Commissioning Report

USE THE FORM ON PAGE 49 TO RECORD SETUP DETAILS AND FAX THEM TO “GTI PRODUCT SUPPORT”, (330) 545-9005.

NOTE: FAILURE TO FAX THIS FORM MAY VOID APPLICABLE WARRANTIES.

6.0 STANDARD KIT CONTENTS AND REQUIRED OPERATING PROGRAM

Series	Mixer(s)	Standard Items			Required Operating Program (See Form GPN0100, GPN1000, or GPN2010 OM)
		Gas Train Kit	Panel Accessory Kit	Panel	
A-E13*	1 x 3"	GGT0311-12	GPA0010-10	GPN0100-12	
A-E14*	1 x 4"	GGT0411-12	GPA0010-10	GPN0100-12	
A-A14*	1 x 4"	GGT0411-12	GPA0005-10	GPN1000-12	DE-1510 STANDARD PROGRAM
I-E15	1 x 5"	GGT0501B	GPA0010-20	GPN0100	
I-A15	1 x 5"	GGT0501A GGT0501B	GPA0005	GPN1000	DE-1510 STANDARD PROGRAM
II-A16	1 x 6"	GGT0601	GPA0005	GPN1000	DE-1510 STANDARD PROGRAM
II-B26	2 x 6"	GGT0602			
III-A16	1 x 6"	GGT0601	GPA0001	GPN1000	DE-1510 STANDARD PROGRAM
III-B26	2 x 6"	GGT0602	GPA0002	GPN2010V	KIT B (GPA0002 PANEL ACCESSORY KIT)
III-B46	4 x 6"	GGT0603			
III-C26	2 x 6"	GGT0602	GPA0003	GPN2010V	KIT C (GPA0003 PANEL ACCESSORY KIT)
III-C46	4 x 6"	GGT0603			
III-D26	2 x 6"	GGT0602	GPA0004	GPN2010V	KIT D (GPA0004 PANEL ACCESSORY KIT)
III-D46	4 x 6"	GGT0603			
IV-B110	1 x 10"	GGT1001	GPA0002	GPN2010V	KIT B (GPA0002 PANEL ACCESSORY KIT)
IV-B27	2 x 7"	GGT0701			
IV-B46	4 x 6"	GGT0604			
IV-B47	4 x 7"	GGT0702			
IV-C27	2 x 7"	GGT0701	GPA0003	GPN2010V	KIT C (GPA0003 PANEL ACCESSORY KIT)
IV-C46	4 x 6"	GGT0604			
IV-C47	4 x 7"	GGT0702			
IV-D27	2 x 7"	GGT0701	GPA0004	GPN2010V	KIT D (GPA0004 PANEL ACCESSORY KIT)
IV-D46	4 x 6"	GGT0604			
IV-D47	4 x 7"	GGT0702			

* Requires 12Vdc supply, all other kits require 24Vdc supply.

REFER TO FORM GPN0100 OM, GPN1000 OM OR GPN2010 OM FOR DETAILED PROGRAMMING INFORMATION.

DE-3010 controllers supplied in kits are configured for two vibration sensors, but may require configuration for English/Metric units. DE-1510 controllers are pre-programmed assuming one vibration sensor is in use and will require re-programming if this is not the case, or to change from English to Metric units. Controllers supplied loose as spares may be shipped with a default program as follows:

DE-1510 systems: Standard program; English units; 1 vibration sensor

DE-3010 systems: Kit B (GPA0002 Panel Accessory Kit); English units; 2 vibration sensors

7.0 GAS TRAIN ASSEMBLY GUIDE, **SERIES A WITH 1 MIXER**

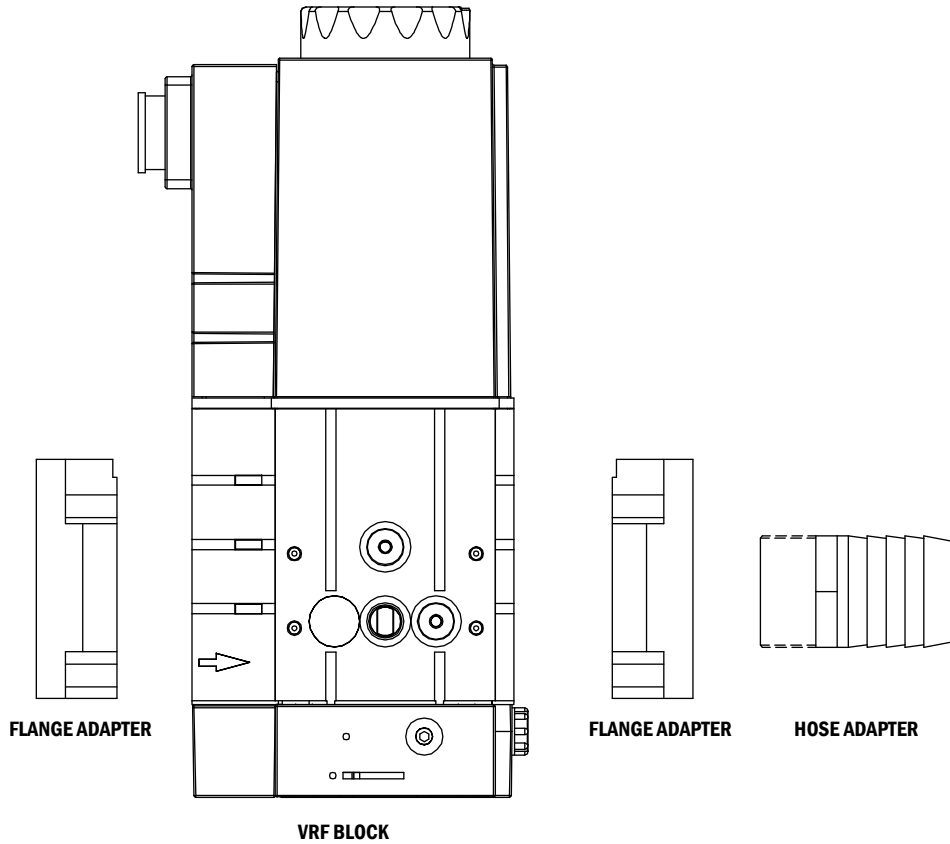

ITEM DESCRIPTION	GAS TRAIN P/N GGT0311-12 SERIES A 1 X 3" MIXER SIZE: 1" NPT		GAS TRAIN P/N GGT0411-12 SERIES A 1 X 4" MIXER SIZE: 1" NPT		MANUFACTURER'S LITERATURE REFERENCE
		QTY.		QTY.	
VALVE-REGULATOR-FILTER (VRF) BLOCK	GSV010-12	1	GSV010-12	1	
ADAPTER, FLANGE TO PIPE	G11021	2	G11021	2	
HOSE ADAPTER	G11028	1	G11028	1	
MIXER *	GMX0031AA	1	GMX0041AA	1	
APPROX. ASSEMBLED DIMENSIONS					
LENGTH	7.6" / 194 MM		7.6" / 194 MM		
WIDTH	3.4" / 87 MM		3.4" / 87 MM		
HEIGHT	9.0" / 232 MM		9.0" / 232 MM		

* NOTE: MIXER LOCATION DEPENDS UPON INSTALLATION AND IS NOT SHOWN IN DRAWING ABOVE.

8.0 GAS TRAIN ASSEMBLY GUIDE, SERIES I WITH MIXER

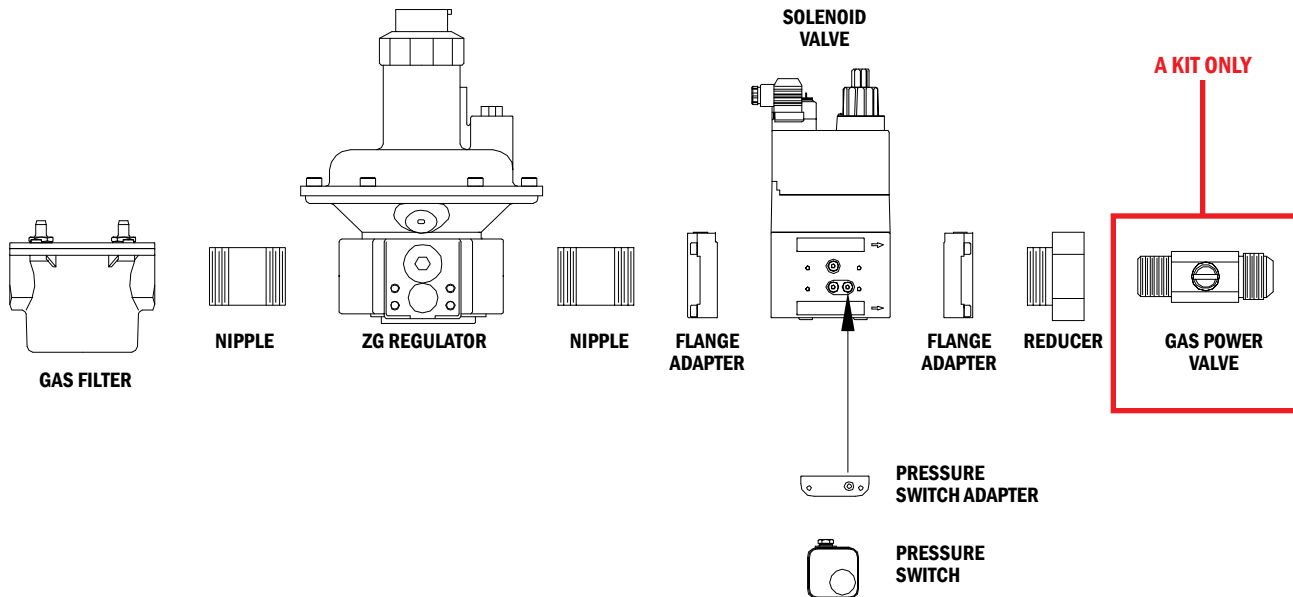

ITEM DESCRIPTION	GAS TRAIN P/N GGT0501A SERIES I 1 X 5" MIXER SIZE: DN50		GAS TRAIN P/N GGT0501B SERIES I 1 X 5" MIXER SIZE: DN50		MANUFACTURER'S LITERATURE REFERENCE	
		QTY.		QTY.		
GAS FILTER	GFL005	1	GFL005	1	MBH2068	
ZERO GAS (ZG) REGULATOR	GGR005	1	GGR005	1	FRG/6	226363, 80116
DUAL MODULAR VALVE (DMV) SOLENOID	GSV004	1	GSV004	1	DMV-DLE/6	226377, 80119
PRESSURE SWITCH (ROP)	G11012	1	G11012	1	GMHA2	226359, 80111
PRESSURE SWITCH ADAPTER	G11013	1	G11013	1		
NIPPLE	G11055	2	G11055	2		
ADAPTER, FLANGE TO PIPE	G11003	2	G11003	2		
REDUCER BUSHING	G11014	1	G11014	1		
GAS POWER VALVE (GPV)	GPV1015AAT	1	INCLUDED IN MIXER			
MIXER *	GMX0050AAT	1	GMX0051AAT	1		
APPROX. ASSEMBLED DIMENSIONS						
LENGTH	31" / 787 MM		31" / 787 MM			
WIDTH	10" / 254 MM		10" / 254 MM			
HEIGHT	13" / 330 MM		13" / 330 MM			

* NOTE: MIXER LOCATION DEPENDS UPON INSTALLATION AND IS NOT SHOWN IN DRAWING ABOVE.

9.0 GAS TRAIN ASSEMBLY GUIDE, **SERIES II, III WITH 1 MIXER**

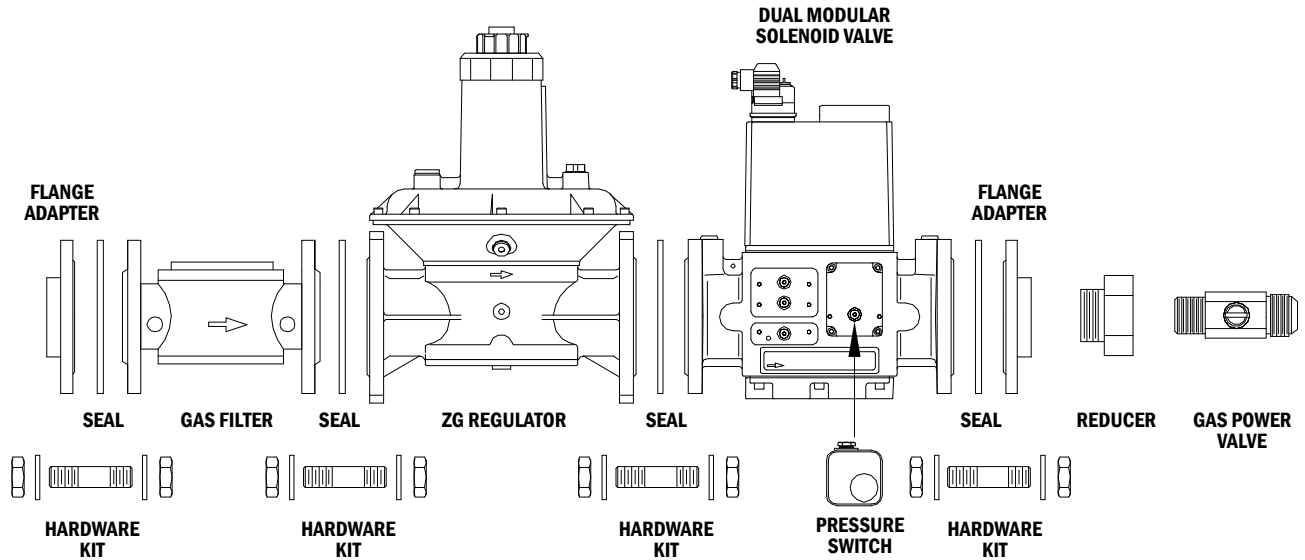

ITEM DESCRIPTION	GAS TRAIN P/N GGT0601 SERIES II/III 1 X 6" MIXER SIZE: DN65	QTY.	MANUFACTURER'S LITERATURE REFERENCE	
GAS FILTER	GFL002	1	GF/3	215204, 222686
ZERO GAS (ZG) REGULATOR	GGR006	1	FRNG	219570, 223842
DUAL MODULAR VALVE (DMV) SOLENOID	GSV005	1	DMV-D11	218376, 222115
PRESSURE SWITCH (ROP)	G11012	1	GMHA2	226359, 80111
ADAPTER, FLANGE TO PIPE	G11007	2		
SEAL	G12020	4		
HARDWARE KIT	G11002	16		
REDUCER BUSHING	G11015	1		
GAS POWER VALVE (GPV)	GPV1015AAT	1		
MIXER *	GMX0060AAT	1		
APPROX. ASSEMBLED DIMENSIONS				
LENGTH	42" / 1067 MM			
WIDTH	11" / 279 MM			
HEIGHT	16" / 406 MM			

* NOTE: MIXER LOCATION DEPENDS UPON INSTALLATION AND IS NOT SHOWN IN DRAWING ABOVE.

10.0 GAS TRAIN ASSEMBLY GUIDE, SERIES II, III, IV WITH 2 MIXERS

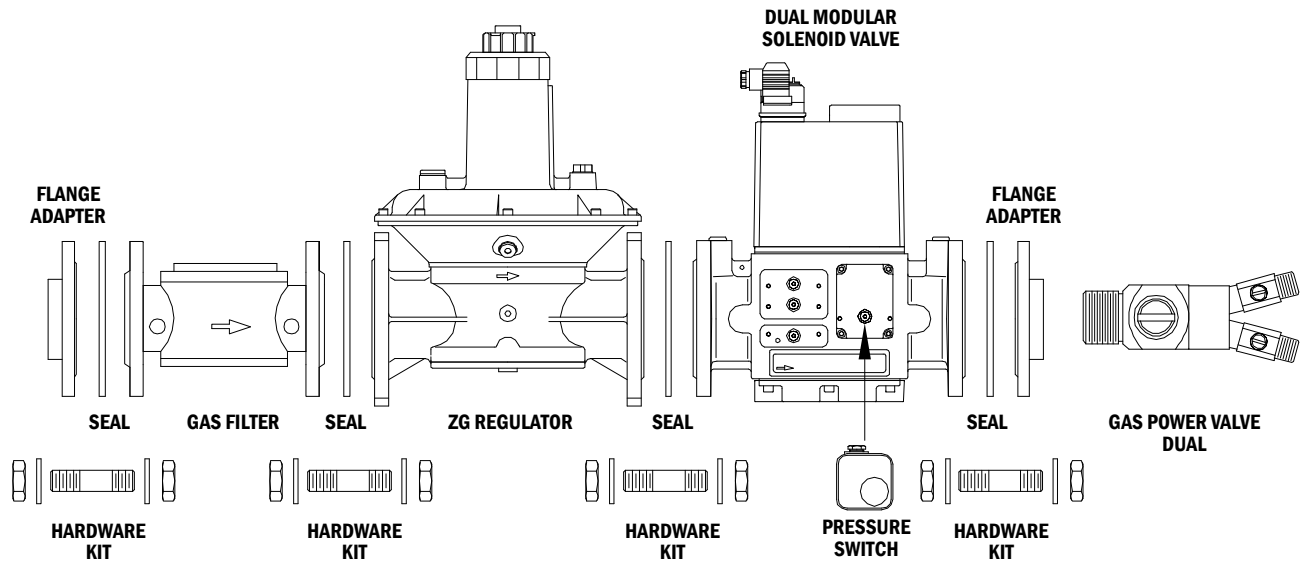

ITEM DESCRIPTION	GAS TRAIN P/N GGT0602 SERIES II/III 2 X 6" MIXER SIZE: DN65		GAS TRAIN P/N GGT0701 SERIES IV 2 X 7" MIXER SIZE: DN80		MANUFACTURER'S LITERATURE REFERENCE	
		QTY.		QTY.		
GAS FILTER	GFL002	1	GFL003	1	GF/3	215204, 222686
ZERO GAS (ZG) REGULATOR	GGR006	1	GGR007	1	FRNG	219570, 223842
DUAL MODULAR VALVE (DMV) SOLENOID	GSV005	1	GSV006	1	DMV-D11	218376, 222115
PRESSURE SWITCH (ROP)	G11012	1	G11012	1	GMHA2	226359, 80111
ADAPTER, FLANGE TO PIPE	G11007	2	G11008	2		
SEAL	G12020	4	G12021	4		
HARDWARE KIT	G11002	16	G11002	32		
GAS POWER VALVE (GPV)	GPV2025AAT	1	GPV2030AAT	1		
MIXER *	GMX0060AAT	2	GMX0070AAT	2		
APPROX. ASSEMBLED DIMENSIONS						
LENGTH	47" / 1194 MM		50" / 1270 MM			
WIDTH	11" / 279 MM		11" / 279 MM			
HEIGHT	16" / 406 MM		16" / 406 MM			

* NOTE: MIXER LOCATION DEPENDS UPON INSTALLATION AND IS NOT SHOWN IN DRAWING ABOVE.

11.0 GAS TRAIN ASSEMBLY GUIDE, SERIES III/IV WITH 4 MIXERS

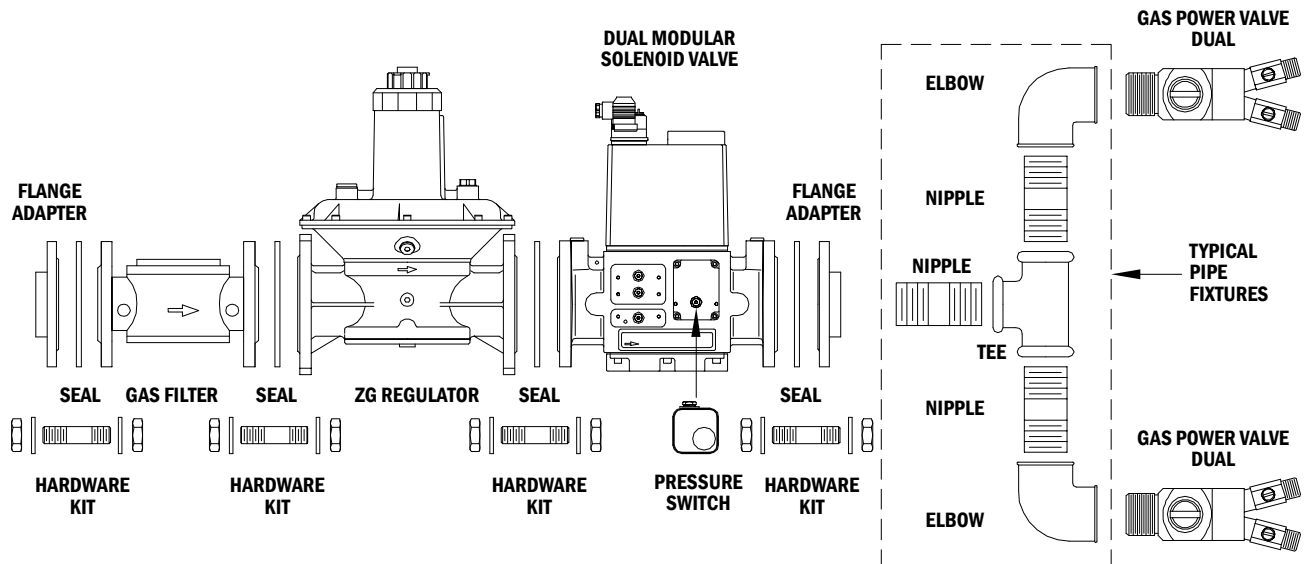

Item Description	Gas Train P/N GGT0603 Series III 4 X 6" Mixers Size: DN65		Gas Train P/N GGT0604 Series IV 4 X 6" Mixers Size: DN80		Gas Train P/N GGT0702 Series IV 4 X 7" Mixers Size: DN80		Manufacturers Literature Reference	
	Qty.		Qty.		Qty.			
Gas Filter	GFL002	1	GFL003	1	GFL003	1	GF/3	215204, 222686
Zero Gas (ZG) Regulator	GGR006	1	GGR007	1	GGR007	1	FRNG	219570, 223842
Dual Modular Valve (DMV) Solenoid	GSV005	1	GSV006	1	GSV006	1	DMV-D11	218376, 222115
Pressure Switch (ROP)	G11012	1	G11012	1	G11012	1	GMHA	2226359, 80111
Adapter, Flange to Pipe	G11007	2	G11008	2	G11008	2		
Seal	G12020	4	G12021	4	G12021	4		
Hardware Kit	G11002	16	G11002	32	G11002	32		
Gas Power Valve (GPV)	GPV2025AAT	2	GPV2030AAT	2	GPV2030AAT	2		
Mixer*	GMX0060AAT*	4	GMX0060AAT*	4	GMX0070AAT*	4		

APPROX. ASSEMBLED DIMENSIONS

LENGTH	ASSEMBLED DIMENSIONS MAY VARY DEPENDING UPON USER-SELECTED COMPONENTS AND PLACEMENT
WIDTH	
HEIGHT	

* NOTE: MIXER LOCATION DEPENDS UPON INSTALLATION AND IS NOT SHOWN IN DRAWING ABOVE.

12.0 SENSOR SPECIFICATIONS

ENGINE EXHAUST GAS TEMPERATURE THERMOCOUPLE – EGT

P/N TCK0420-SS or TCK0430-SS
Metal transition w/strain relief and 0.25" x 4" 304SS sheath
Fiberglass stranded overbraid leadwire ungrounded
Type K (32°F to 2300°F)
Fitting: 1/8 inch NPT

MANIFOLD AIR TEMPERATURE THERMOCOUPLE – MAT

P/N TCK0420-SS or TCK0430-SS
Metal transition w/strain relief and 0.25" x 4" 304SS sheath
Fiberglass stranded overbraid leadwire Ungrounded
Type K (32°F to 2300°F)
Fitting: 1/8 inch NPT

MANIFOLD AIR PRESSURE SENSOR – MAP

P/N 691201-50
0-50psig Pressure Transducer
+5Vdc Excitation Voltage
0.5-4.5Vdc Output Voltage
75psig Overload Rating
250psig Bursting Rating
1% Accuracy of Span
Operating Temp. Range -40°F. to 221°F
Fitting: 1/8 inch NPT

ENGINE VACUUM SENSOR – VAC

P/N 691206-50
0-50PSIA Pressure Transducer
+5Vdc Excitation Voltage
0.5-4.5Vdc Output Voltage
75PSIA Overload Rating
250PSIA Bursting Rating
1% Accuracy of Span
Operating Temp. Range -40°F to 221°F
Fitting: 1/8 inch NPT

ENGINE VIBRATION SENSOR – VIB

P/N 691205
4-20mA output proportional to velocity
Supply voltage: 24Vdc
Environmental rating: NEMA 4X
Enclosure MATerial: 303SST
Electrical connection: 18 AWG wire
Frequency response: up to 2000Hz
Operating temp. range: -40°F to 221°F
Mounting: 1/4 inch NPT
(Supplied Heat Sink Adaptor Mounting: 3/8"-16)

GAS SUPPLY PRESSURE SENSOR -GSP

P/N 691201-15
0-15psig Pressure Transducer
+5Vdc Excitation Voltage
0.5-4.5Vdc Output Voltage
22.5psig Overload Rating
75psig Bursting Rating
1% Accuracy of Span
Operating Temp. Range -40°F. to 221°F.
Fitting: 1/8 inch NPT

REGULATOR OUTPUT PRESSURE SWITCH -ROP

P/N G11012
SPDT switch
NC contact breaks on increasing psig
Contact rating: 10A res., 8 FLA, 48 LRA @ 120VAC
NEMA Type 4 enclosure
MAXIMUM pressure 7psig (1496.2mbar)
Ambient temp. range -40°F to +140°F

GLOSSARY OF TERMS

AAAC	Air to Air Aftercooling
BMEP	Brake Mean Effective Pressure
BTU	British Thermal Unit
CAD	Computer-Aided Design
CH4	Methane Molecule
CNC	Computer Numeric Control (Machining)
DGCS	Dynamic Gas Control System
DMV	Dual Modular Valve Gas Solenoid
EGT	Engine Exhaust Gas Temperature
GEG	Gas Equivalent Gallon
GEL	Gas Equivalent Liter
GPV	Gas Power Valve
GSP	Gas Supply Pressure
H2S	Hydrogen Sulfide
HC	Hydrocarbons
HP	Horsepower
ID	Inside Diameter
IPS	Inches Per Second
JIC	Joint Industry Conference (Thread Specification)
JWAC	Jacket Water Aftercooling
KCAL	Kilocalories
KPA	Kilopascal
KWE	Kilowatt Electric
LCD	Liquid Crystal Display
LED	Light Emitting Diode
LEL	Lower Explosive Limit
MAP	Engine Manifold Air Pressure
MAT	Engine Manifold Air Temperature
MBAR	Millibar
MJ	Megajoule
MPS	Millimeters Per Second
NBR	Nitrile Rubber
NPT	National Pipe Thread Tapered
OD	Outside Diameter
OEM	Original Equipment (Engine) Manufacturer
PMAX	Peak Firing Pressure
PSIA	Pounds per Square Inch-Absolute
PSIG	Pounds per Square Inch-Gauge
ROP	Regulator Output Pressure
RPM	Rotations Per Minute (Engine Speed)
SCAC	Separate Circuit Aftercooling
SCF	Standard Cubic Feet
VAC	Engine Vacuum
VIB	Engine Vibration
WC	Water Column
ZG	Zero Gas Pressure Regulator

CONVERSIONS

LENGTH

MULTIPLY	→→→→→	TO GET
TO GET	←←←←←	DIVIDE
inch	2.54	cm
feet	12	inch
feet	0.305	meter
yard	1.094	meter
Angstrom	1010	meter

FLOWRATE

MULTIPLY	→→→→→	TO GET
TO GET	←←←←←	DIVIDE
cc/min	1	mL/min
cfm (ft ³ /min)	28.31	L/min
cfm (ft ³ /min)	1.699	m ³ /hr
cfh (ft ³ /hr)	472	mL/min
cfh (ft ³ /hr)	0.125	GPM
GPH	63.1	mL/min
GPH	0.134	cfh
GPM	0.227	m ³ /hr
GPM	3.785	L/min
oz/min	29.57	mL/min

CONVERSIONS

PRESSURE (LIQUID PUMPS)

MULTIPLY	→→→→→	TO GET
TO GET	←←←←←	DIVIDE
psig	2.31	feet of water
psia	6.9	kilopascals
psig	2.03	inches of Hg
psia	0.068	atm
psia	0.068	bar
atm	33.9	feet of water
atm	760	mm Hg
inches Hg	1.133	feet of water
mm Hg	0.039	inches Hg
newtons/m ²	1	pascals

PRESSURE / VACUUM

MULTIPLY	→→→→→	TO GET
TO GET	←←←←←	DIVIDE
atm	33.9	feet of water
atm	760	mm Hg
atm	1033.2	g/cm ²
atm	14.70	psia
atm	1.013	bar
atm	101.3	kPa
bar	14.5	psia
bar	0.9869	atm
bar	100	kPa
feet of water	0.4335	psia
kPa	0.01	dyne/cm ²
kPa	0.1450	psia
kPa	7.5	mm Hg
psi	0.0703	kg/cm ²

CONVERSIONS

VOLUME (LIQUID PUMPS)

MULTIPLY	→→→→→	TO GET
TO GET	←←←←←	DIVIDE
gallons	128	fluid ounces
gallons	3.785	liters
liters	1000	cubic centimeters
pounds of water	0.119	gallons
gallons (Imperial)	1.2	gallons (U.S.)
cubic feet	7.48	gallons
cubic inches	0.00433	gallons
cubic centimeters	0.0338	fluid ounces
cubic meters	264.2	gallons
cubic meters	1000	liters

MISCELLANEOUS

MULTIPLY	→→→→→	TO GET
TO GET	←←←←←	DIVIDE
hp	0.746	kW
hp	42.44	BTU/min
hp	396,000	lb in/min
hp	1.014	metric hp
watts	0.7376	lb ft/sec
watts	44.25	lb ft/min
lb-foot	0.1368	kg-m
oz-in	0.072	kg-cm
oz-in	70,600	dyne-cm
oz-in	0.00706	Nm
gauss	0.0001	tesla

CONVERSIONS

VOLUME

MULTIPLY	→→→→→	TO GET
TO GET	←←←←←	DIVIDE
cubic cm (cc)	1	milliliters (mL)
ounces (fluid)	29.57	milliliters (mL)
cubic feet (ft ³)	7.48	gallons
cubic feet (ft ³)	0.0283	cubic meters (m ³)
gallons	128	liters
gallons	3.785	ounces (fluid)
gallons	0.8333	imperial gallons
cubic meters (m ³)	1000	liters

DENSITY CONVERSIONS

Specific Gravity x 1 = g/L
 g/L x 8.345404 = lb/gal
 lb/gal x 0.119826 = g/mL

TEMPERATURE

°F = (1.8 x °C) + 32
 °C = (°F - 32) x 0.555
 °Kelvin = °C + 273.2

This page left blank intentionally.



COMMISSIONING REPORT

GENERAL INFORMATION		BI-FUEL® SYSTEM INFORMATION			
TECHNICIAN:		BI-FUEL® SYSTEM MODEL:			
DATE OF COMMISSIONING:		GPN1000 or 2XXX:			
DATE OF INSTALLATION:		DISPLAY SERIAL NUMBER:			
		TERMINAL SERIAL NUMBER:			
CUSTOMER:		STANDARD or DGCS:			
END USER:		FIRMWARE DATE:			
LOCATION:		OBSERVED ENGINE DATA			
ENGINE/GENSET SERIAL NO.		100% DIESEL		BI-FUEL®	
ENGINE/GENSET ARRANGE. NO.		KW/HP		KW/HP	
ENGINE/GENSET MODEL:		MAT 1		MAT 1	
ENGINE/GENSET RATING(S):		MAT 2		MAT 2	
ACTUAL MINIMUM LOAD:		EGT1		EGT 1	
ACTUAL MAXIMUM LOAD:		EGT1		EGT 1	
TYPICAL LOAD		VIB1		VIB 1	
PARALLELING OPERATION (DESCRIBE):		VIB2		VIB 2	
GAS TYPE:		GSP		GSP	
GAS ANALYSIS ATTACHED?:					
COMMENTS		ESTIMATED GAS RATIO		DE-1510/3010 SETPOINTS	
		MEASURED WITH:		LOW	HIGH
				MAT 1	
		25% LOAD		MAT 2	
		50% LOAD		EGT 1	
		75% LOAD		EGT 2	
		100% LOAD		VIB 1	
				VIB 2	
	CUSTOMER INFORMATION			GSP	
	CONTACT:			ROP	N/A
	TELEPHONE:			MAP 1	
	E-MAIL:			MAP 2	

Please FAX completed form to (330) 545-9005